



KRATOS EQUIPMENT
 7750 Georgetown Road, Indianapolis, IN 46268
 Sales: (317) 634-2550
 Tech Service: (887) 368-2797

Project Name: _____

Location: _____

Item #: _____ Qty: _____

Model: _____

REACH-IN FREEZERS

Model: 69K-765HC 1 Doors 69K-774HC 2 Doors



69K-765HC
1 Door



69K-774HC
2 Door

KRATOS bottom mount reach-in freezers are built to last and operate efficiently for years. Temperature is digitally controlled and readily adjusted for ideal storage conditions maintaining the product freshness and shelf life. The large LED temperature display is easily viewed from the exterior of the cabinet. The stainless steel exterior and interior construction ensures years of long life, easy to clean surfaces and maximum durability. KRATOS units are designed to meet the requirements of the most discriminating customer. Each model comes includes a condensate evaporator, avoiding the need for a drain connector.

FEATURES

- Stainless steel exterior and painted aluminum interior ensures years of long life, maximum durability and are easy to clean
- High R-value, CFC-free polyurethane foam insulation
- 3 heavy-duty, adjustable, PE coated wire shelves per section
- Door locks for security
- 5" swivel casters come standard (2 with brakes)
- Automatic defrost system keeps the unit at peak operating condition
- Digitally controlled temperature system maintains optimum storage temperature and is easily adjusted
- Self-closing doors with heavy-duty hinges
- LED lighting

TEMPERATURE

- Recommended holding temperature range: -10°F to 10°F (-23° to -12°C)
- Comes factory set to -4°F (-20°C)
- Open door alert, beeps if a door has been inadvertently left open
- Automatic programmable defrost

CONSTRUCTION

- Interior lighting controlled by an on-off door switch
- Integral condensate evaporator eliminates need for a floor drain connection
- Self contained heavy-duty refrigeration system - forced air for even temperature regulation, fast product cooling and rapid recovery
- Easy to grip handles formed into the door
- Heavy-duty hinges that open to 180°
- Heavy-duty corrosion-resistant shelves and adjustable mounting clips

REFRIGERANT

Environmentally-friendly R290a

ELECTRIC

115/60Hz/1 Ph (NEMA 5-15)

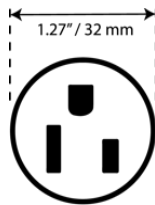

NEMA 5-15P



Intertek
Conforms to
ANSI-NSF 7



Intertek
Conforms to
ANSI UL 471



Environmentally
Friendly



EPA
Approved
Insulation &
Refrigerant



DOE 2017
Compliant

KRATOS WARRANTY (USA / CANADA)

One (1) year parts
 One (1) year on-site labor
 Four (4) additional years (Five (5) total) for the compressor (part only)
 Administered by KRATOS EQUIPMENT, 887.368.2797
 24/7 tech support provided

Due to periodic changes in designs, methods, procedures, policies and regulations, the specifications contained in this sheet are subject to change without notice. While we exercise good faith efforts to provide information that is accurate, we are not responsible for errors or omissions in information provided or conclusions reached as a result of using the specifications.

By using the information provided, the user assumes all risks in connection with such use.

The built in performance enhancing functions ensure that given proper attention and preventative maintenance, each KRATOS Product will deliver years of trouble free, reliable, low maintenance, efficient operation.



KRATOS EQUIPMENT
 7750 Georgetown Road, Indianapolis, IN 46268
 Sales: (317) 634-2550
 Tech Service: (887) 368-2797

Project Name: _____
 Location: _____
 Item #: _____ Qty: _____
 Model: _____

REACH-IN FREEZERS

69K-765HC

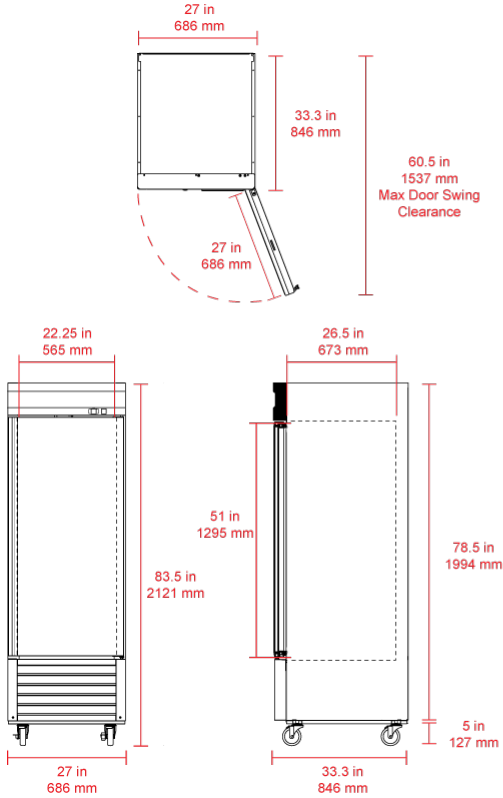

69K-774HC

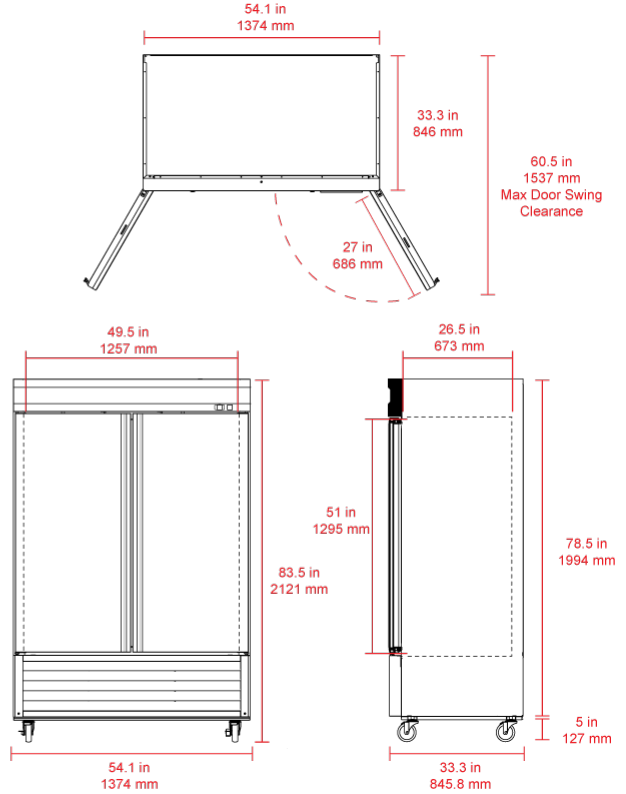

The overall height of the unit may be reduced by over 2" with an optional shorter caster set of 4 heavy duty casters (2 come with brakes).

	69K-765HC	69K-774HC
In: External Dimensions W x D X H	27 x 33.3 x 83.5	54.1 x 33.3 x 83.5
mm: External Dimensions W x D X H	686 x 846 x 2121	1374 x 846 x 2121
Nominal Capacity	23 Cu Ft / 652 L	49 Cu Ft / 1388 L
Actual Storage Capacity	19.3 Cu Ft / 547 L	42.9 Cu Ft / 1215 L
Doors (Self Closing)	1	2
Shelves	3	6
Unit Weight	280 lbs / 127 kg	470 lbs / 213 kg
Shipping Weight	318 lb / 140 kg	512 lb / 233 kg)
Watt Rating	402.5 W	943 W
Amp Draw	3.5	8.2
Refrigerant	R290a 4.9 oz	R290a 4.6 oz
Factory Temperature Setting	-4°F (-20°C)	-4°F (-20°C)

Due to periodic changes in designs, methods, procedures, policies and regulations, the specifications contained in this sheet are subject to change without notice.
 While we exercise good faith efforts to provide information that is accurate, we are not responsible for errors or omissions in information provided or conclusions reached as a result of using the specifications.
 By using the information provided, the user assumes all risks in connection with such use.