



KRATOS EQUIPMENT
 7750 Georgetown Road, Indianapolis, IN 46268
 Sales: (317) 634-2550
 Tech Service: (887) 368-2797

Project Name: _____
 Location: _____
 Item #: _____ Qty: _____
 Model: _____

SANDWICH STATION

Model: 69K-835HC



69K-835HC

KRATOS Sandwich Stations provide the perfect blend of durability and accessibility to allow for quick and easy preparation of sandwiches, salads and more. The stainless steel exterior ensures easy cleaning, longevity and minimal maintenance. Products are held in a storage environment to preserve freshness and prolong shelf life.

FEATURES

- Easy to grip recessed door handles
- 4 Casters (2 locking, 2 non-locking)
- Adjustable, heavy-duty wire shelves (1 per section/door)
- 11.42" deep polyethylene cutting board is included on all models
- Comes with full set of clip on divider bars and 4" deep plastic pans

TEMPERATURE

- Holding temperature: 34° to 41°F (1° to 5°C)
- Forced-air refrigeration delivers consistent temperature regulation
- Solid-state controls deliver consistent, easily adjustable temperature performance

CONSTRUCTION

- Exterior Material: Durable, easy to clean stainless steel
- Interior Material: Powder coated aluminum
- CFC Free, high R-value foamed in place polyurethane insulated walls and doors
- Integral condensate evaporator so no floor drain connection is needed

REFRIGERANT
 Environmentally-friendly R290a

ELECTRIC
 120/60Hz/1 Ph (NEMA 5-15)

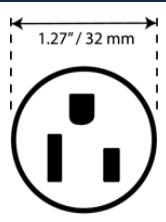

NEMA 5-15P



KRATOS WARRANTY (USA / CANADA)

One (1) year parts
 One (1) year on-site labor
 Four (4) additional years (Five (5) total) for the compressor (part only)
 Administered by KRATOS EQUIPMENT, 887.368.2797
 24/7 tech support provided

Due to periodic changes in designs, methods, procedures, policies and regulations, the specifications contained in this sheet are subject to change without notice. While we exercise good faith efforts to provide information that is accurate, we are not responsible for errors or omissions in information provided or conclusions reached as a result of using the specifications. By using the information provided, the user assumes all risks in connection with such use.

The built in performance enhancing functions ensure that given proper attention and preventative maintenance, each KRATOS will deliver years of trouble free, reliable, low maintenance, efficient operation.

SANDWICH STATION

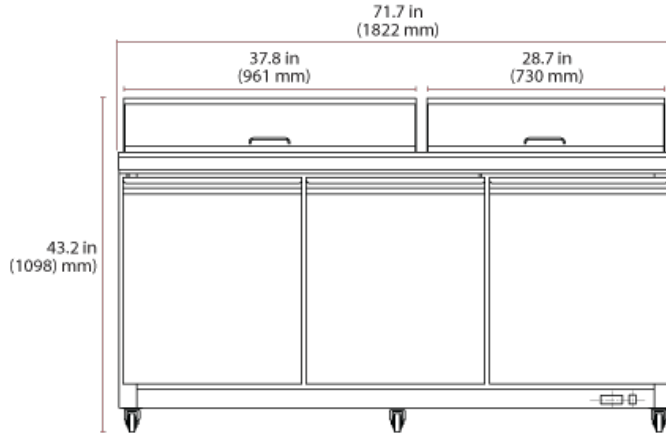

69K-835HC

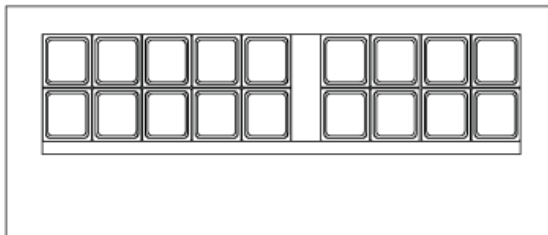
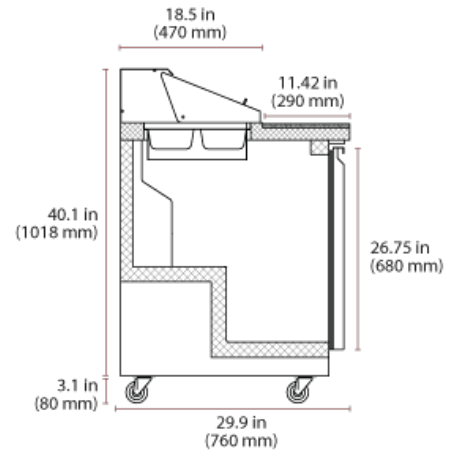

	External Dimensions in / mm	Internal Dimensions In /mm	Capacity	Temperature Range	Max Amp Draw	R290a Charge Size	Unit Weight	Shipping Weight	Pans (1/6)
69K-835HC	71.7 x 29.9 x 43.2 1822 x 760 x 1098	66.9 x 18.8 x 22 1700 x 478 x 558	18 Cu Ft 510 L	34°- 41° F 1°- 5° C	8	3.35 oz	381 lb 173 kg	422 lb 191 kg	18

Due to periodic changes in designs, methods, procedures, policies and regulations, the specifications contained in this sheet are subject to change without notice. While we exercise good faith efforts to provide information that is accurate, we are not responsible for errors or omissions in information provided or conclusions reached as a result of using the specifications. By using the information provided, the user assumes all risks in connection with such use.