



Specifications

F.O.B St. Louis, Missouri 63102



613Q-G2
(Shown w/optional casters)

OPTIONS:

- Stainless steel interior
- Stainless steel back enclosure panel
- Seismic feet
- 48" flexible disconnect, w/restraining device
- Down draft hood
- Common gas manifold
- Double stack - shipped assembled
- Flue deflector
- Casters
- Porcelain drip tray
- Extra oven racks - standard and deep depth
- Prison package - tamper proof screws, lexan hinged cover with lockable clasp
- Extended warranty

AGENCY LISTINGS:



DUKE MANUFACTURING CO.
2305 N. Broadway
St. Louis, MO 63102

800.735.3853 Toll Free
314-231-1130 In Missouri
314.231.5074 Fax
www.dukemfg.com

Approval Stamp(s):

PRODUCT INFORMATION:

PROJECT: _____

ITEM: _____

QUANTITY: _____

MODEL:

Duke Convection Ovens - "Q" Series Double Section - Standard Depth - Gas

- 613Q-G2** Double section, standard depth

STANDARD FEATURES:

- 6 racks/13 rack positions
- Porcelain interior finish
- 50/50 independent stainless steel doors
- Doublepane glass both doors
- 8" angular stainless steel legs/adjustable feet

OVEN SECTION:

- Stainless steel front, sides and top
- 1-1/2" insulation on bottom, sides and back
- 3" insulation on top

OVEN CONTROLS:

- "V" - Basic snap action thermostat (200°- 500°F), 60 minute electric dial timer with continuous sound buzzer, 2-speed fan
- "XX" - Solid state digital time and temperature controls, 12-hour countdown timer, **Cook and Hold** feature, 2-speed fan, Pulse fan capability

SHORT FORM SPECIFICATIONS:

Duke Convection Ovens - "Q" Series -Gas - Double Section - Standard Depth.

Front, sides, top, door, interior door liners and door gaskets shall be constructed of stainless steel. Porcelain interior finish, with 6 racks and 13 rack positions, and 7/8" coved corners. Unit shall have independently opening doors and 8" angular stainless steel legs with adjustable feet. Unit shall have 50/50 stainless steel doors with doublepane glass in both doors. Doors shall be mounted on full length solid steel shafts and bronze bushings. Interior lighting to be (2) 50 watt, 155v bulbs. Bottom, sides and back shall be fully insulated with 1-1/2" thick insulation, top to have 3" thick insulation. Units shall have 40,000 BTU input, electronic relight systems. 1/2 HP two speed blower motor, 115v, ON-OFF-COOL Down switch, manual gas shut-off on control panel. Built-n gas pressure regulator. Overall dimensions of unit shall be: 70-1/2" height, including 8" legs, 38" width, depth of 39-1/2" and cavity dimensions of 29"W x 24"H x 24"D.

DUKE CONVECTION OVENS
"Q" SERIES - DOUBLE SECTION - GAS - STANDARD DEPTH

613Q-G2 Double section, standard depth

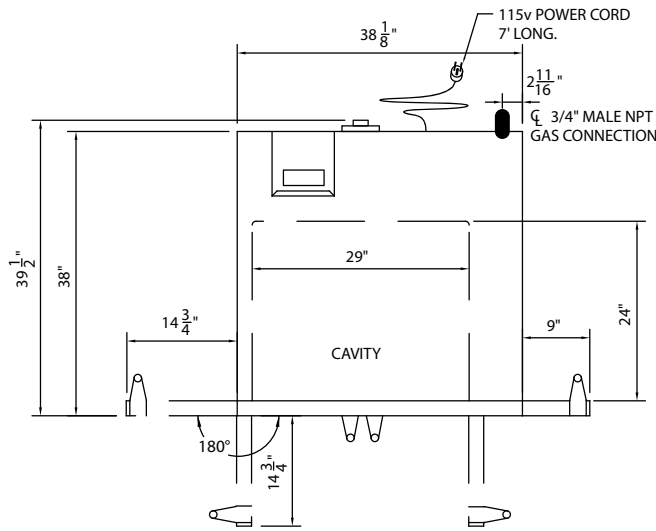

TOP VIEW

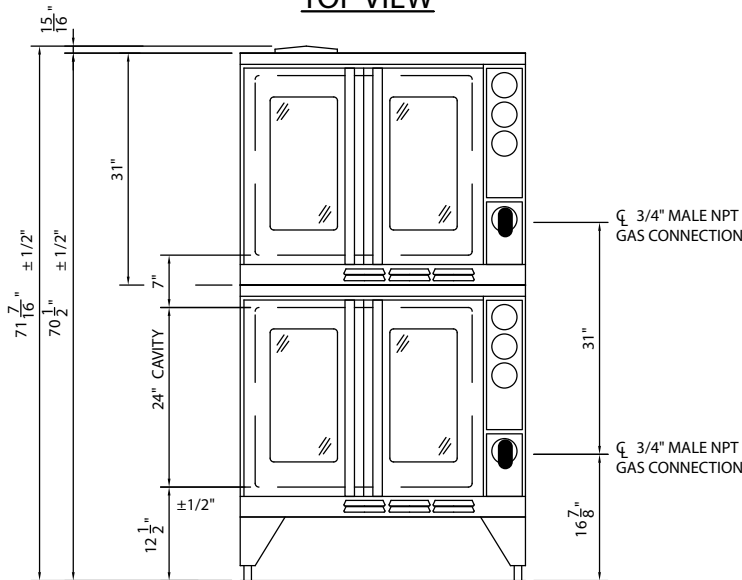

FRONT VIEW

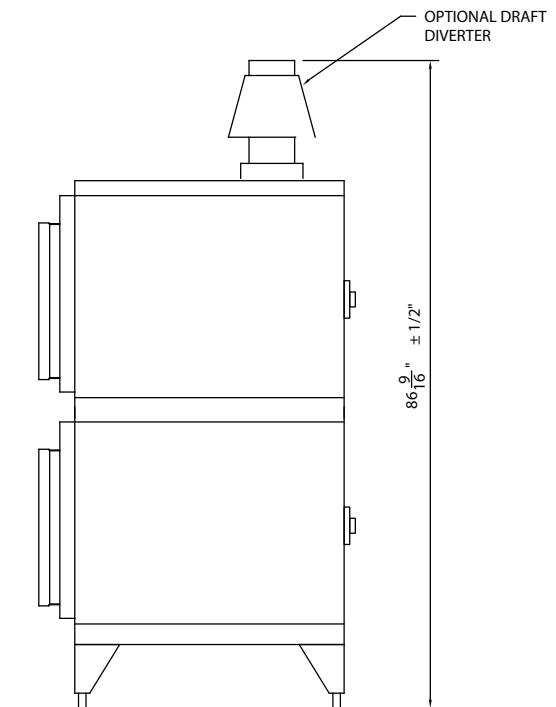

RIGHT SIDE VIEW

Gas Specifications	
	BTU/Hour
613Q-G2	40,000
Regulated gas pressure required 3.5" WC natural /10" WC propane	
Combustible surface clearance - 1" side, 1" rear, 6" floor	
■ - Gas connection	
3/4" Gas connection	
Electrical requirements: 3.5 Amps/ 115V	
Standard 115V units supplied with 5' cord and plug	

DIMENSIONS:

FREIGHT CLASS: 85

Model	Depth front view		Width		Height top view		Cube ft. crated	Weight	
	in	cm	in.	cm	in.	cm		lbs	kg
613Q-G2	39-1/2	100.3	38	96.5	70--1/2	179.1	69.7	1080	490.0

Specify gas type

Specify altitude over 2000 feet



DUKE MANUFACTURING CO.
 2305 N. Broadway
 St. Louis, MO 63102

800.735.3853 Toll Free
 800.231.1130 In Missouri
 314.231.5074 Fax
www.dukemfg.com

Specification subject to change