



Your Solutions Partner

# Specifications

F.O.B St. Louis, Missouri 63102



**7122A-3072**  
Maple Top w/ Adjustable Undershef



**7123-3072**  
Maple Top w/ Tubular Base

### OPTIONS:

- Stainless steel overshef - 1056
- Cross bracing welded to table
- Casters, swivel, two w/locks, 5" diameter, rubber tires
- Casters, swivel, two w/locks, 5" diameter, polyurethane tires
- Spice bins - **201**
- Portable ingredient bin - **5027**
- 5"H maple riser - specify back only or sides and back - standard or coved
- Stainless steel adjustable bullet feet
- Drawer, standard - **185** or **186**
- Drawer, deluxe - **176** or **177**
- Tiers of drawers - **731** (S/S in & out), **732** (galv in S/S out)

### AGENCY LISTING:



**DUKE MANUFACTURING CO.**  
2305 N. Broadway  
St. Louis, MO 63102

800.735.3853 Toll Free  
314.231.1130 In Missouri  
314.231.5074 Fax  
www.dukemfg.com

SS-DM-00218-AW-07

### Approval Stamp(s):

### PRODUCT INFORMATION:

PROJECT: \_\_\_\_\_  
ITEM: \_\_\_\_\_  
QUANTITY: \_\_\_\_\_

MODEL:

### Duke Worktables - Maple Top Tables

- 7121A** Galvanized undershef/galvanized legs/plastic feet
- 7122A** Stainless steel undershef/stainless steel legs & feet
- 7123** Galvanized tubular bracing/galvanized legs/plastic feet
- 7124** Stainless steel tubular bracing/stainless steel legs & feet

### TOP:

- 1-3/4" thick laminated edge-grained hard maple

### ADJUSTABLE UNDERSHELF:

- Heavy gauge galvanized or stainless steel, as specified
- Die-formed corners
- Set screws to lock in place

### LEGS:

- Galvanized leg sockets
- Non-marking, non-corrosive, adjustable plastic bullet feet for galvanized legs
- Stainless steel feet for stainless steel legs
- 1-5/8" diameter, S/S or galvanized tubular legs

### CROSS BRACING:

- 1-5/8" stainless steel or galvanized steel tubing
- 10" from floor
- Attached with slotless, contour-head bolts

Click here to buy now!



1-866-285-1252

### SHORT FORM SPECIFICATIONS:

**Duke Worktables - Maple Top Tables.** Top shall be constructed of 1-3/4" thick laminated edge-grained hard maple. Adjustable undershef to be or heavy gauge galvanized or stainless steel with aluminum die-cast corners to provide tight sanitary contact with legs. Locks in place with set screws at any height. If adjusted to less than 6" from floor, tables will not be NSF approved. Bracing can be ordered welded integrally to table. Legs shall have heavy gauge galvanized leg sockets screwed securely to underside of top and designed to provide maximum rigidity to 1-5/8" diameter, heavy gauge galvanized legs fitted with adjustable plastic bullet feet or stainless steel tubular legs fitted with adjustable stainless steel feet. As option, legs may be fitted with stainless steel feet. Tables 96" or longer to have 6 legs. Also available mounted on NSF approved 5" diameter swivel casters, two with locks, in lieu of adjustable feet. Shipped knocked down for quick, easy assembly.

# Aerohot®

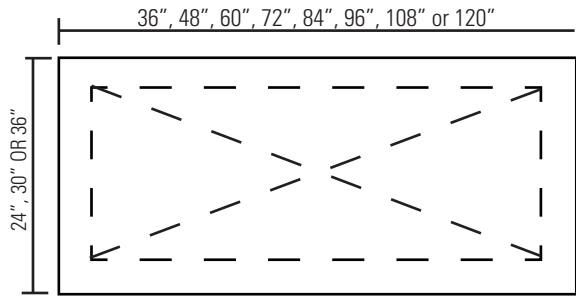

**TOP VIEW**

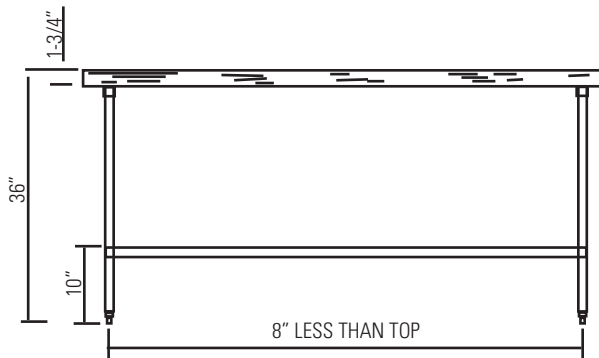

**FRONT VIEW**

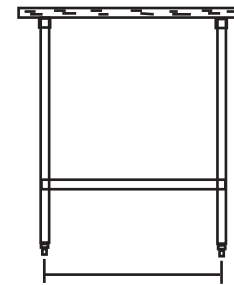

**SIDE VIEW**

## DUKE WORKTABLES MAPLE TOP TABLES

- 7121A** Galvanized undershelf/galvanized legs/plastic feet
- 7122A** Stainless steel undershelf/stainless steel legs & feet
- 7123** Galvanized tubular bracing/galvanized legs/plastic feet
- 7124** Stainless steel tubular bracing/stainless steel legs & feet

**NOTE:** To order tables, add numbers in top widths and top lengths columns to model number for specific table sizes.

**EXAMPLE:** 8121A-2436 for 24" wide x 36" long 7121A table

### DIMENSIONS:

Maple Top Tables with Adjustable Undershelf - Height: 36" (91.4 cm)

Freight Class: 55

Model	Top Width		Cube Feet Crated							
	in.	cm	36"/91.4 cm	48"/121.9 cm	60"/152.4 cm	72"/182.9 cm	84"/213.4 cm	96"/243.8 cm	108"/274.3 cm	120"/304.8 cm
<b>7121A</b> Galv. Undershelf Galv Legs	24	61.0	21.8	28.6	35.5	42.4	49.2	56.1	61.0	69.8
	30	76.2	26.8	35.2	43.7	52.1	60.6	69.0	77.5	86.0
	36	91.4	31.8	33.5	51.9	61.9	72.0	82.0	92.0	102.1
<b>7122A</b> S/S Undershelf S/S Legs	24	61.0	21.8	28.6	35.5	42.4	49.2	56.1	63.0	69.8
	30	76.2	26.8	35.2	43.7	52.1	60.6	69.0	77.5	86.0
	36	91.4	31.8	33.5	51.9	61.9	72.0	82.0	92.0	102.1

Maple Top Tables with Tubular Base - Height: 36" (91.4 cm)

Model	Top Width		Cube Feet Crated							
	in.	cm	36"/91.4 cm	48"/121.9 cm	60"/152.4 cm	72"/182.9 cm	84"/213.4 cm	96"/243.8 cm	108"/274.3 cm	120"/304.8 cm
<b>7123</b> Galv. Tubular Bracing Galv Legs	24	61.0	21.8	28.6	35.5	42.4	49.2	56.1	61.0	69.8
	30	76.2	26.8	35.2	43.7	52.1	60.6	69.0	77.5	86.0
	36	91.4	31.8	33.5	51.9	61.9	72.0	82.0	92.0	102.1
<b>7124</b> S/S Tubular Bracing S/S Legs	24	61.0	21.8	28.6	35.5	42.4	49.2	56.1	63.0	69.8
	30	76.2	26.8	35.2	43.7	52.1	60.6	69.0	77.5	86.0
	36	91.4	31.8	33.5	51.9	61.9	72.0	82.0	92.0	102.1



### DUKE MANUFACTURING CO.

2305 N. Broadway  
St. Louis, MO 63102

800.735.3853 Toll Free  
800.231.1130 In Missouri  
314.231.5074 Fax  
www.dukemfg.com

Specification subject to change