



Your Solutions Partner

Specifications

F.O.B Sedalia, Missouri 65301



HB3-1H2C

OPTIONS:

- 8" deep liner in lieu of 5"
- Internal locking device
- 220v - 50 Hz compressor
- Condensate evaporator
- Three phase wiring
- 8' or 10' cord and plug in lieu of 6'
- 1-color laminate on body/second color laminate on tray slide
- Laminate finish other than standard eight (8) finishes
- Heat/lights in canopy
- Kickplates (stainless) (painted) (laminate to match body)
- Heritage laminated trayslides
- End shelf
- Foodshields
- Trayslides
- Bread and cheese board
- False bottom for cold pan
- Legs in lieu of casters

AGENCY LISTING:



DUKE MANUFACTURING CO.
2305 N. Broadway
St. Louis, MO 63102

800.735.3853 Toll Free
314.231.5074 Fax
www.dukemfg.com

SS-DM-00046-HBU-02

Approval Stamp(s):

PRODUCT INFORMATION:

PROJECT: _____

ITEM: _____

QUANTITY: _____

MODEL:

Heritage Buffet - Hot/Cold Cold Pan - 5" Deep

- | | |
|--|--|
| <input type="checkbox"/> HB3-2H1C 2 hot/1 cold | <input type="checkbox"/> HB4-1H3C 1 hot/3 cold |
| <input type="checkbox"/> HB3-1H2C 1 hot/2 cold | <input type="checkbox"/> HB4-3H1C 3 hot/1 cold |
| <input type="checkbox"/> HB5-3H2C 3 hot/2 cold | <input type="checkbox"/> HB4-2H2C 2 hot/2 cold |
| <input type="checkbox"/> HB5-2H3C 2 hot/3 cold | <input type="checkbox"/> HB5-1H4C 1 hot/4 cold |

TOP:

- 16 gauge, 300 Series stainless steel
- Flanged down 2" on all four (4) sides
- Independently operated hot food wells
- Single control mechanically cooled ice pan sections

BODY:

- Heavy gauge paint grip steel
- Laminate patterns:

<input type="checkbox"/> Beige Grafix - HB-01	<input type="checkbox"/> Northern Oak - HB-06
<input type="checkbox"/> Oxide - HB-04	<input type="checkbox"/> Azul Granite - HB-13
<input type="checkbox"/> Fallen Leaves - HB-07	<input type="checkbox"/> Amber Maple - HB-12
<input type="checkbox"/> Chestnut Burl - HB-11	
- Stainless steel trim strips on corners
- Flanged and channeled edges for strength
- Welded together with reinforcements
- Mounted on NSF listed 5" diameter swivel casters, two with locks, all non-marking polyurethane tires

HOT FOOD SECTION:

- Stainless steel liners, 12" x 20", insulated with fiberglass
- Each section to have 500 or 750 watt electric exposed element
- Individual infinite controls
- 6' cord and plug
- Spillage pans included, aluminum

MECHANICALLY ASSISTED ICE PAN SECTION:

- 18 gauge, 300 Series stainless steel liner
- 12-1/16" x 20-1/16" die stamped openings - 5" deep
- Insulated on all four sides and bottom
- 1" cast brass drain and plug
- Refrigerant coils, controls and compressor compartment - R134A

Click here to buy now! **Central** | **1-866-285-1252**
 RESTAURANT PRODUCTS

SHORT FORM SPECIFICATIONS:

Heritage® Buffet - Hot/Cold - 5" Deep Cold Pan. Top shall be 16ga, 300 series Stainless Steel turned down edges, flush at ends, 20ga paint grip steel bodies with laminate and s/s corner trim, die-stamped with 12"x 20" openings for hot and cold sections, cold pans, 5" deep, to have 1" brass drain & plug, s/s grille, fully insulated hot food pans to have infinite controls, 5" dia. NSF approved swivel casters, 2 w/ locks, 6' cord & plug.

Note: Stainless Steel body panels in lieu of laminate not available.

HERITAGE®

Heritage® Buffet - Hot/Cold Cold Pan - 5" Deep

- HB3-2H1C 2 hot/1 cold
- HB3-1H2C 1 hot/2 cold
- HB5-3H2C 3 hot/2 cold
- HB5-2H3C 2 hot/3 cold
- HB4-1H3C 1 hot/3 cold
- HB4-3H1C 3 hot/1 cold
- HB4-2H2C 2 hot/2 cold
- HB5-1H4C 1 hot/4 cold

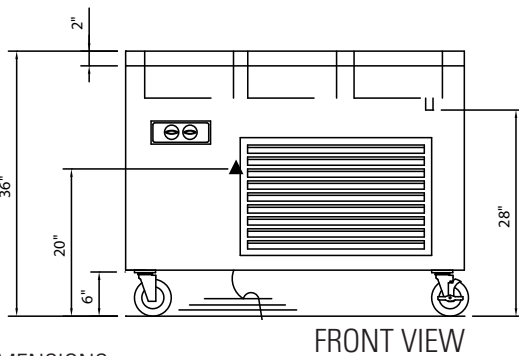
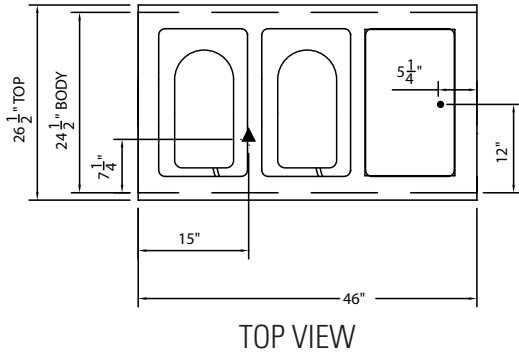

LEGEND	
▲	- ELECTRICAL CONNECTION
●	- DRAIN LOCATION

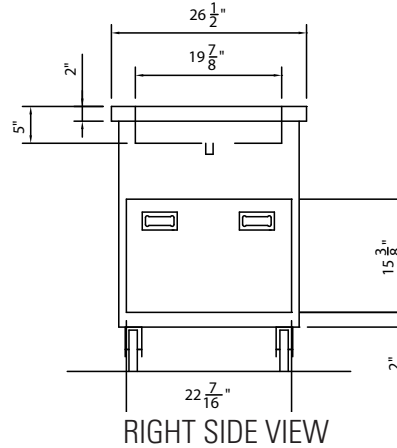

DIMENSIONS:

All Units 26-1/2 (67.3 cm) Wide & 36" (91.4 cm Tall)

FREIGHT CLASS: 150

Model	Length		Cube ft. crated	Weight		Model	Length		Cube ft. crated	Weight	
	in.	cm		lbs.	kg		in.	cm		lbs.	kg
HB3-2H1C	46	116.8	36.0	432	196.4	HB4-1H3C	60	152.4	45.7	570	259.1
HB3-1H2C	46	116.8	36.0	432	196.4	HB5-3H2C	74	188.0	55.4	745	338.6
HB4-2H2C	60	152.4	45.7	570	259.1	HB5-2H3C	74	188.0	55.4	745	338.6
HB4-3H1C	60	152.4	45.7	570	259.1	HB5-1H4C	74	188.0	55.4	745	338.6

ELECTRICAL SPECIFICATIONS:

Model	HP	120 volt - 500 watt elements			120/208 volt - 750 watt elements			120/240 volt - 750 watt elements		
		watts	amps	NEMA	watts	amps	NEMA	watts	amps	NEMA
HB3-2H1C	1/5	1600	13.3	5-15	2100	10.1	L14-30	2100	8.8	L14-30
HB3-1H2C	1/5	1100	9.2	5-15	1350	6.3	L14-30	1350	5.8	L14-30
HB4-2H2C	1/5	1600	13.3	5-15	2100	9.9	L14-30	2100	9.0	L14-30
HB4-3H1C	1/5	2100	17.5	L5-30	2850	13.5	L14-30	2850	12.1	L14-30
HB4-1H3C	1/5	1100	9.2	5-15	1350	6.3	L14-30	1350	5.8	L14-30
HB5-3H2C	1/5	2150	17.5	L5-30	2900	13.5	L14-30	2900	12.1	L14-30
HB5-2H3C	1/5	1650	13.4	5-15	2150	9.9	L14-30	2150	9.0	L14-30
HB5-1H4C	1/4	1280	10.7	5-15	1530	9.6	L14-30	1530	9.1	L14-30

DUKE MANUFACTURING CO.

2305 N. Broadway
St. Louis, MO 63102

800.735.3853 Toll Free
800.231.1130 In Missouri
314.231.5074 Fax
www.dukemfg.com

