

MODEL: _____ PROJECT: _____ ITEM #: _____ QTY: _____

PRODUCT IMAGE



FMC24-SS-R SHOWN

STANDARD FEATURES

- **Electrical**
115 V, 1 Phase, 60 Hz. Furnished with 8'-0" plug-in cord. NEMA 5-15P Plug Configuration. Dedicated 15 Amp circuit recommended
- **Refrigeration**
1/3 HP, 404 refrigerant
- **Running Load (Amps)**
24" Unit: 5.2 Amps
- **Operating Range**
-5°F to 5°F
- **Door Opening Dimensions**
24 3/4" x 19 15/16"
- **Plumbing**
No drain connection required
Condensate evaporates automatically
- **Insulation**
2" thick foamed-in-place polyurethane
- **Mug Capacity (10 oz.)**
24" Unit: 90
- All stainless interior with coved corners
- Self-contained refrigeration
- Available with black vinyl or stainless steel exterior
- -5°F to 5°F temperature range with digital thermostat set to 0°F
- Automatic defrost timer every 4 hours (Pushbutton manual mode also available)
- Floor rack and two levels of shelves
- Heavy-duty doors
- Easy to service
- 5 year compressor warranty
- **IMPORTANT NOTE:**
DO NOT PLUG INTO GFI OUTLET

OPTIONAL ACCESSORIES

- **MC-100** Four 6" Stainless Steel Legs
- **MC-102** Four 4" Stainless Steel Legs
- **MC-106** Left Side Stainless Steel Kick Plate
- **MC-107** Right Side Stainless Steel Kick Plate
- **MC-108** Four 3" Casters with brakes
- **MC-124** 24" Stainless Steel Front Kick Plate

[Click here to buy now!](#)



1-866-285-1252



** This equipment is not intended for storage or display of food or beverages **

APPROVED BY:

CERTIFICATIONS:

Due to our commitment to continued product improvement, specifications are subject to change without notice.

Printed in the USA

Krowne Metal Corporation

100 Haul Rd. Wayne, NJ 07470 • Toll Free: (800) 631-0442 • Fax: (973) 872-1129
 sales@krowne.com • www.krowne.com • www.facebook.com/KrowneMetal • www.twitter.com/KrowneMetal

Rev. 12/2012
No. 1.8

MODEL: _____ PROJECT: _____ ITEM #: _____ QTY: _____

24" FRONT DOOR MUG FROSTER

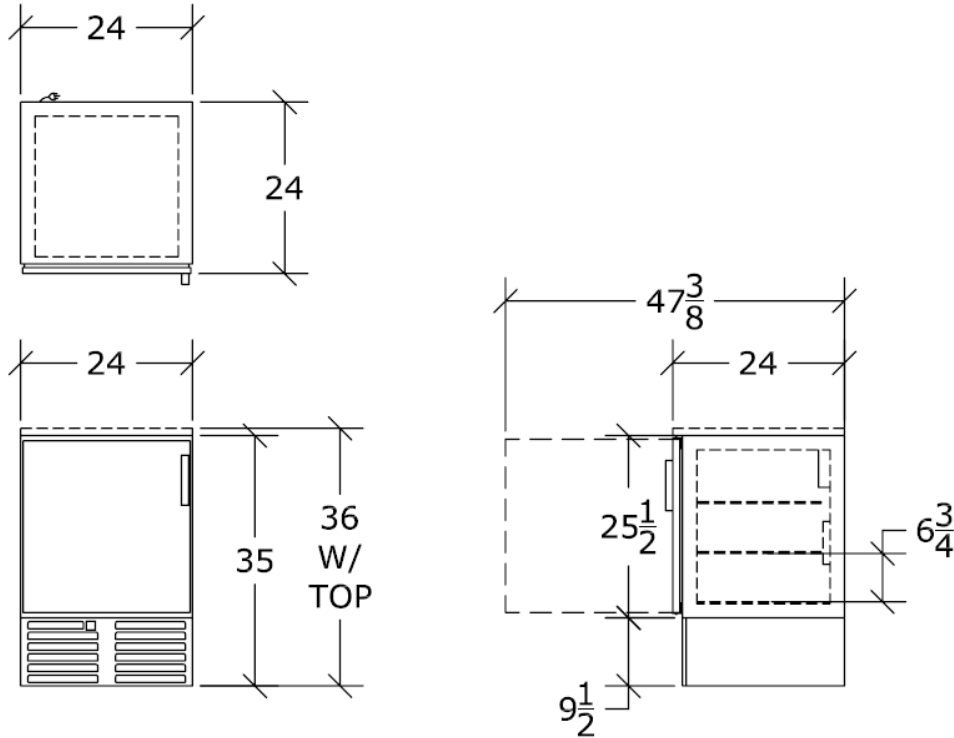

Model Numbers	Exterior Finish	Top Finish	Door Opening Dimensions (H x W)	Door Hinge	Weight (lbs.)
FMC24-BN-L	Black Vinyl	Unfinished	24 3/4" x 19 15/16"	Left	220
FMC24-BN-R	Black Vinyl	Unfinished	24 3/4" x 19 15/16"	Right	220
FMC24-BS-L	Black Vinyl	Stainless Steel	24 3/4" x 19 15/16"	Left	244
FMC24-BS-R	Black Vinyl	Stainless Steel	24 3/4" x 19 15/16"	Right	244
FMC24-SN-L	Stainless Steel	Unfinished	24 3/4" x 19 15/16"	Left	220
FMC24-SN-R	Stainless Steel	Unfinished	24 3/4" x 19 15/16"	Right	220
FMC24-SS-L	Stainless Steel	Stainless Steel	24 3/4" x 19 15/16"	Left	244
FMC24-SS-R	Stainless Steel	Stainless Steel	24 3/4" x 19 15/16"	Right	244



CERTIFICATIONS:

APPROVED BY:

Due to our commitment to continued product improvement, specifications are subject to change without notice.