



Model: 20-201L Item #: \_\_\_\_\_ Date: \_\_\_\_\_  
 Project: \_\_\_\_\_ Qty: \_\_\_\_\_ Approved By: \_\_\_\_\_

# Single Hole Deck Mount Pot Filler

Royal Series Plumbing



20-201L

## Standard Features

- 1/4 turn high performance ceramic cartridge valves with integral check
- Built-in backflow preventers
- Built-in vacuum breaker
- 72" stainless steel clad flexible hose, tested to 400 PSI
- Plastic coated wall hook with chrome plated base
- Mounting kit included
- Full replacement parts available
- 1 year warranty

## Specifications

Water Inlet	1/2" NPT Male
Mounting Style	Deck Mount
Shank	1-1/8" OD x 2-1/2"
Centers	Single Hole
Rough In	1-1/4" Round Hole
Temp. Range	40° - 180°F
Material	Solid Brass
Finish	Chrome Plated Finish
Weight	9 lbs.

## Product Compliance

- NSF-61 & NSF/ANSI 372
- ASME A112.18.1-2012/CSA B125.1-12

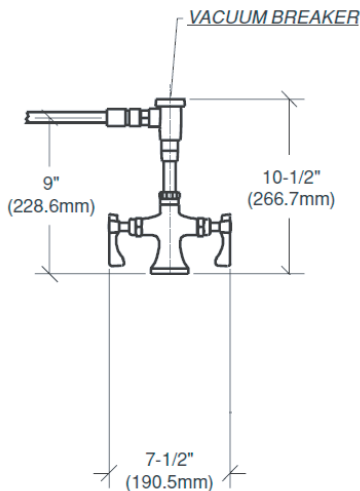

Front View

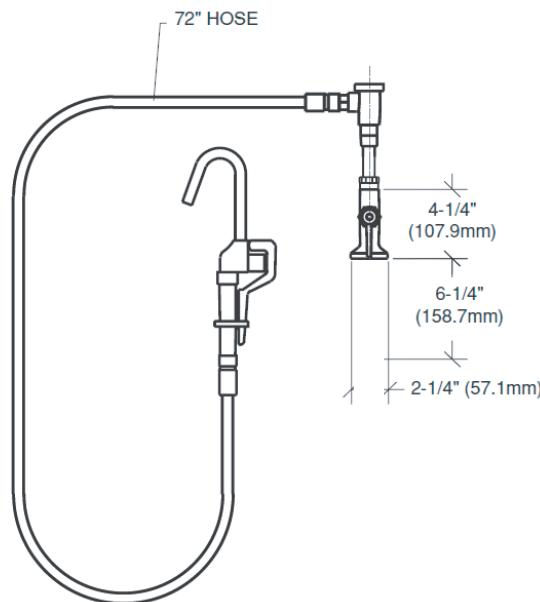

Side View

### WARNING:

Plumbing connections should be made by qualified personnel who will observe all applicable plumbing, sanitary and safety codes.

### California Prop 65 Warning:

This product can expose you to chemicals including lead and lead compounds, which are known to the State of California to cause cancer and birth defects or other reproductive harm. For more information go to [www.P65Warnings.ca.gov](http://www.P65Warnings.ca.gov).