

# TECHNICAL DATA SHEET

## **VENUE® TABLETOP NAPKIN DISPENSER**

### FOR INTERFOLD

#### **H4003TBK**

- Compact – saves space on counters, tabletops, or concession areas
- One-at-a-time napkin dispensing – hygienic and cost efficient
- Advertising Insert – promote and market your products or events
- NSF Approved – easy to clean
- Dispenses interfold napkins

**Color:** Transparent Black

#### **Advertising Insert:**

6.5" x 4.25"

#### **Item Dimensions:**

7.56"w x 6.57"d x 6.18"h

#### **Carton Dimensions:**

8"w x 6.75"d x 6.56"h

#### **Capacity:**

200 interfold napkins

**Unit Weight:** 1.45 lbs.

**Boxed Weight:** 1.75 lb.

**Units/Case:** 4

**Case Weight:** 7.92 lbs.

#### **Master Case Dimensions:**

13.75"w x 16.375"d x 7.5"h

#### **Materials:**

*Dispenser Body & Faceplate: Transparent ABS*

*Insert/Plate: High Impact Polystyrene Plastic*

*Spring: Stainless Steel*

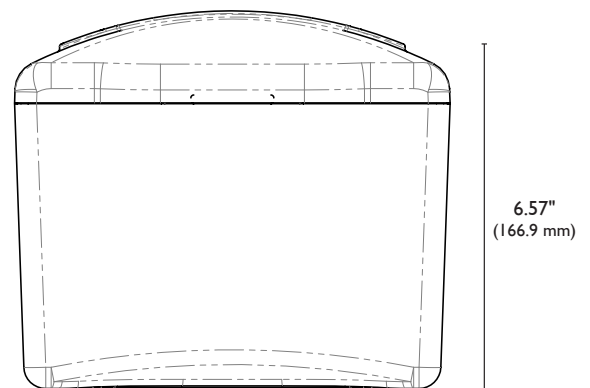
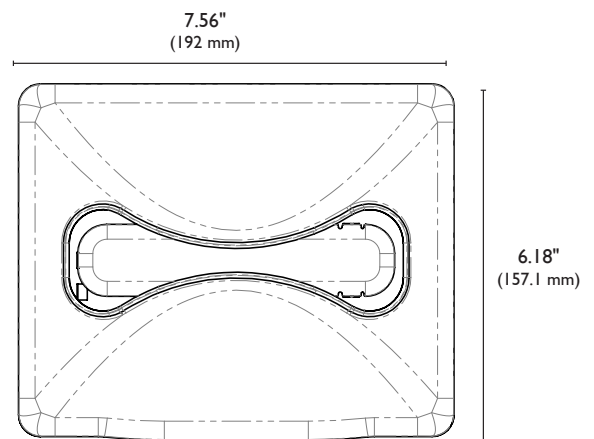

**San Jamar**  
555 Koopman Lane  
Elkhorn, Wisconsin 53121  
USA  
T: +1.262.723.6133  
F: +1.262.723.4204  
info@sanjamar.com  
www.sanjamar.com

**Canada**  
3300 Bloor Street West  
Center Tower, 11th Floor  
Suite 3140 Toronto, ON  
M8X 2X3  
CANADA  
T: +1.416.760.7367  
F: +1.416.207.2071  
canada@sanjamar.com

**Europe**  
Schoorstraat 26a, bus 1  
2220 Heist op-den Berg  
BELGIUM  
T: +32 1522 8140  
F: +32 1522 8148  
emea@sanjamar.com

**México**  
Av. Universidad #1377-701  
Colonia Axotla CP 01030  
Del. Alvaro Obregón  
MEXICO, D.F.  
T: +52 (55) 3626 0772  
F: +52 (55) 5273 4495  
mexico@sanjamar.com

 **san jamar®**  
smart. safe. sanitary.