



Features

- Uniformly Toasts Regular Bread, Texas Toast, Frozen Waffles, and Many Other Foods
- Full brushed stainless steel housing
- Easily Replaceable Industrial Heating Plates
- Standard 4-slice, combination bread and bagel and dedicated bagel toasters available
- Bagel Slots Toast on Cut Side Only
- Electronic Browning Controls
- Carriage Control Levers
- Dishwasher-Safe Crumb Tray
- Limited One Year Warranty

Heavy-Duty Commercial, Combination & Bagel Toasters



WCT810/WCT815/WCT815B
Combination Toasters



WCT820
Bagel Toaster



WCT800RC/WCT800
WCT805/WCT805B
Standard 4-Slice Toasters





Heavy-Duty Commercial, Combination & Bagel Toasters

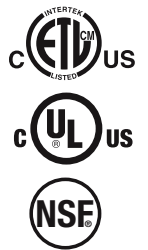

Specifications

Item	Electrical	Listings	Watts	Amps	Plug	Dimensions (H" x W" x D")	Warranty
WCT800RC	120 Volt, 50/60 Hz	UL, CUL, NSF	1800	15	NEMA 5-15P Ⓢ	9" x 11 7/8" x 10 1/2"	Limited 1 Year
WCT800	120 Volt, 50/60 Hz	ETL, NSF	2200	19	NEMA 5-20P Ⓢ	9" x 11 7/8" x 10 1/2"	Limited 1 Year
WCT805B	208 Volt, 50/60 Hz	UL, CUL, NSF	2700	13	NEMA 6-15P Ⓢ	9" x 11 7/8" x 10 1/2"	Limited 1 Year
WCT805	240 Volt, 50/60 Hz	UL, CUL, NSF	2700	12	NEMA 6-15P Ⓢ	9" x 11 7/8" x 10 1/2"	Limited 1 Year
WCT810	120 Volt, 50/60 Hz	ETL, NSF	2025	17	NEMA 5-20P Ⓢ	9" x 11 7/8" x 10 1/2"	Limited 1 Year
WCT815B	208 Volt, 50/60 Hz	UL, CUL, NSF	2025	10	NEMA 6-15P Ⓢ	9" x 11 7/8" x 10 1/2"	Limited 1 Year
WCT815	240 Volt, 50/60 Hz	UL, CUL, NSF	2025	9	NEMA 6-15P Ⓢ	9" x 11 7/8" x 10 1/2"	Limited 1 Year
WCT820	120 Volt, 50/60 Hz	ETL, NSF	1500	12.5	NEMA 5-15P Ⓢ	9" x 11 7/8" x 10 1/2"	Limited 1 Year

Ordering Information

Description	Catalog #	Std Pkg.	Ship Wt. (Lbs.)	Cubic Feet	UPC Code
Heavy-Duty 120V Standard Toaster	WCT800RC	1	22 lbs.	1.6	040072002915
Heavy-Duty 120V Standard Toaster	WCT800	1	22 lbs.	1.6	040072001451
Heavy-Duty 208V Standard Toaster	WCT805B	1	22 lbs.	1.6	040072003196
Heavy-Duty 240V Standard Toaster	WCT805	1	22 lbs.	1.6	040072001468
Heavy-Duty 120V Combination Toaster	WCT810	1	22 lbs.	1.6	040072001475
Heavy-Duty 208V Combination Toaster	WCT815B	1	22 lbs.	1.6	040072003219
Heavy-Duty 240V Combination Toaster	WCT815	1	22 lbs.	1.6	040072001482
Heavy-Duty 120V Bagel Toaster	WCT820	1	22 lbs.	1.6	040072010019

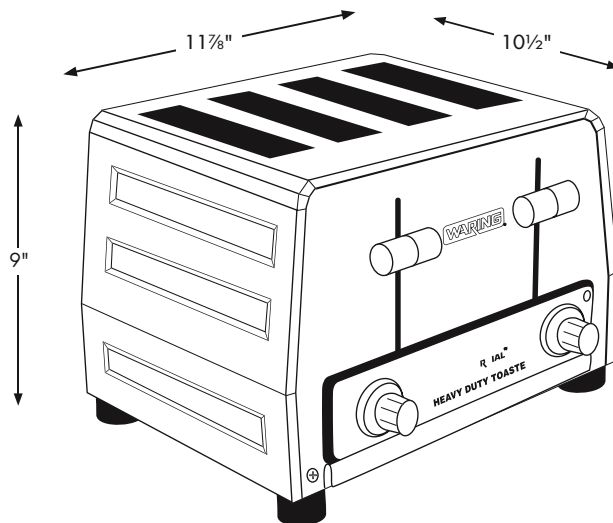

**Measurements are the same for all models.*

Waring Commercial • 314 Ella T. Grasso Ave. • Torrington • Connecticut 06790
 Tel. (800) 492-7464 • Fax (860) 496-9008 • www.waringproducts.com • ©2007 Waring

07WC30102
 PG-21496