



WSG30

Commercial, Heavy-Duty Electric Spice Grinder



MAIN FEATURES

- Finely grinds hard spices and seeds such as cinnamon sticks, nutmeg, peppercorns and more — the most efficient tool for creating spice blends, rubs, pastes and marinade mixture.
- High-performance, commercial-grade motor operates at 19,000 RPM
- Heavy-duty, brushed stainless steel housing features an interlocking safety lid
- PULSE function lets you control the texture and consistency of your grind
- Includes 3 removable and dishwasher-safe, stainless steel grinding bowls with storage lids to conveniently store ground spices, sealed for freshness
- Durable, stainless steel blades are built specifically to create fine grinds and maximize motor efficiency
- Limited One-Year Warranty

ELECTRICAL

Voltage: 120

Frequency: 60Hz

Watts: 175

Amps: 1.4

Plug Type: NEMA 5-15P

Cord Length: 5 feet



SALES FEATURES

Grind up the freshest ingredients effortlessly and in time with the Waring® WSG30 Commercial, Heavy-Duty Electric Spice Grinder. It's perfect for peppercorns, cinnamon sticks, star anise, nuts and much more. Grinding your own spices means you can maintain a large stock of whole spices longer, without reordering or risking stale product.



@waringcommercial

©2019 Waring Commercial
314 Ella T. Grasso Avenue, Torrington, CT 06790
Tel. 800-492-7464 • Fax 860-496-9008

waringcommercialproducts.com

Commercial, Heavy-Duty Electric Spice Grinder

WSG30



PARTS & ACCESSORIES



CAC103 Stainless Steel Bowl with Lid

DIMENSIONS

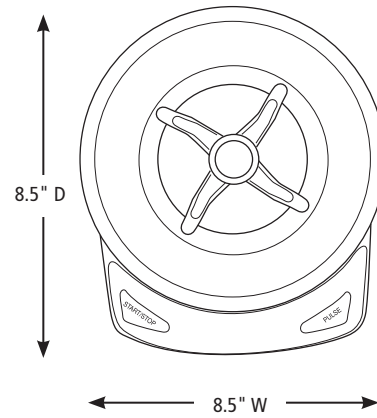
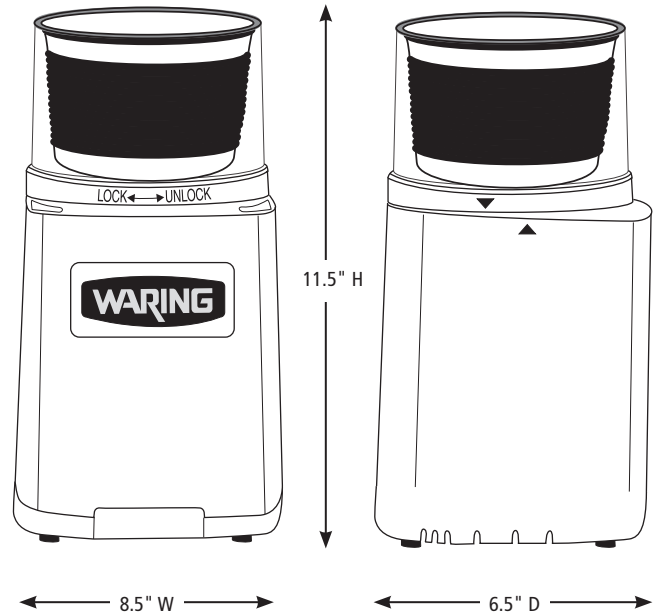

Out of Box Weight: 6 lb.

ORDERING INFORMATION	#STD. PKG.	GIFTBOX WEIGHT	CUBIC FEET	BOX DIMENSIONS D X W X H	UPC	CASE PKG.	MC WEIGHT	MC DIMENSIONS D X W X H	MBC
WSG30 – Heavy-Duty Electric Spice Grinder	1	4.5	.436	10.5" x 7.2" x 9.8"	040072610798	4	19.1	21.2" x 15.1" x 10.2"	10040072010795



@waringcommercial

©2019 Waring Commercial
314 Ella T. Grasso Avenue, Torrington, CT 06790
Tel. 800-492-7464 • Fax 860-496-9008

waringcommercialproducts.com

19WC061597/ REV 09/19