



MX1300XTS

Reprogrammable Hi-Power Blender with 64 oz., Stainless Steel Container



*Made in USA with US and foreign parts.

ELECTRICAL

Voltage: 120

Frequency: 60Hz

Watts: 1560

Amps: 12.5

Plug Type: NEMA 5-15P

Cord Length: 6 feet



MAIN FEATURES

- Heavy-duty, 3.5 peak HP, high-performance motor with 2 speed selections is the strongest in its class. It powers through the toughest ice and frozen fruit mixtures in seconds
- Super-high, 45,000 RPM motor speed for the smoothest consistencies
- 4 reprogrammable beverage settings for perfect results every time
 - Factory-set programs for the most popular beverage types
 - Easy to create your own customized programs—fully reprogrammable directly on the keyboard. No need for a USB or computer for programming
- Dual PULSE feature with reprogrammable speed control
- Easy-to-clean, electronic-membrane keypad
- Premium, stainless steel container with 64 oz. capacity and cloverleaf jar design creates a high-power vortex, funneling food directly into the blade. Unbreakable and dishwasher safe
- High-performance, high-impact, stainless steel blade is user replaceable for easy servicing
- User-replaceable, metal-on-metal, stainless steel coupling system for durability and reliability
- Easily removable container cover with removable clear cap lets you add ingredients and reduce pressure during hot food blending
- Optional sound enclosure easily retrofits to base for noise reduction
- Recommended for 75+ drinks per day
- Limited Three-Year Motor Warranty and Two-Year Parts and Labor Warranty

SALES FEATURES

Get smooth, consistent results every time with the Waring® MX1300XTS. This heavy-duty, 3.5 HP blender teams up with The Raptor® blade and jar assembly for maximum power and efficiency. The sturdy base features an easy-to-clean, electronic-membrane keypad with blue backlit LCD screen and four reprogrammable beverage settings. Perfect for a busy bar, health facility, school or coffee shop.

Reprogrammable Hi-Power Blender with 64 oz., Stainless Steel Container

MX1300XTS



@waringcommercial

©2020 Waring Commercial
314 Ella T. Grasso Avenue, Torrington, CT 06790
Tel. 800-492-7464 • Fax 860-496-9008

waringcommercialproducts.com



Reprogrammable Hi-Power Blender with 64 oz., Stainless Steel Container MX1300XTS

PARTS & ACCESSORIES

- | | | | |
|---|--|---|--|
|  | CAC90
64 oz. Stainless Steel Container |  | CAC95-12
64 oz. Green Copolyester Container |
|  | CAC93X
48 oz. Copolyester Container |  | CAC95-28
64 oz. Orange Copolyester Container |
|  | CAC93X-03
48 oz. Yellow Copolyester Container |  | CAC116
Blending Assembly Kit and Retainer Ring Kit |
|  | CAC93X-06
48 oz. Blue Copolyester Container |  | CAC119
Retainer Ring Wrench |
|  | CAC93X-10
48 oz. Purple Copolyester Container |  | CAC158
Blending Assembly Kit |
|  | CAC93X-12
48 oz. Green Copolyester Container |  | CAC159
Retainer Ring Kit |
|  | CAC93X-28
48 oz. Orange Copolyester Container |  | CAC160
Drive Coupling |
|  | CAC95
The Raptor® – Aggressive, All-Purpose, Stackable, 64 oz., BPA-Free Copolyester Container |  | CAC161
Drive Coupling Removal Tool |
|  | CAC95-03
64 oz. Yellow Copolyester Container |  | CAC169
Spatula – Custom designed for use with MX Series Blenders |
|  | CAC95-06
64 oz. Blue Copolyester Container |  | SE1000
Large Sound Enclosure |
|  | CAC95-10
64 oz. Purple Copolyester Container |  | SE500
Small Sound Enclosure |

DIMENSIONS

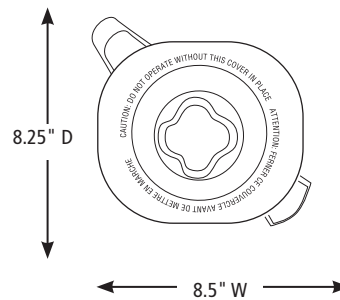
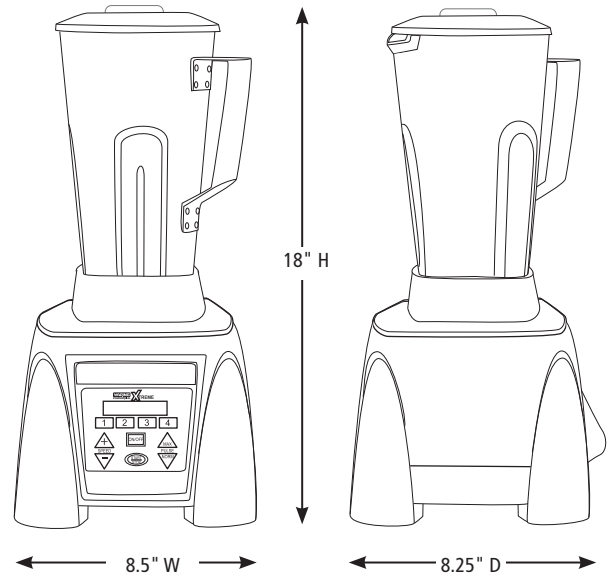

Out of Box Weight: 17 lb.

ORDERING INFORMATION	#STD. PKG.	GIFTBOX WEIGHT	CUBIC FEET	BOX DIMENSIONS D X W X H	UPC	CASE PKG.	MC WEIGHT	MC DIMENSIONS D X W X H	MBC
MX1300XTS– Reprogrammable Hi-Power Blender with 64 oz., Stainless Steel Container	1	18.15	1.037	11.375" x 10.250" x 15.375"	040072006852	1	19.1	11.875" x 10.875" x 16.375"	10040072006859



@waringcommercial

©2020 Waring Commercial
314 Ella T. Grasso Avenue, Torrington, CT 06790
Tel. 800-492-7464 • Fax 860-496-9008

waringcommercialproducts.com

20WC072682 / REV 02/20