

**SCR1156**

58.38" x 23.63" x 22.88" (H x W x D)

Commercial beverage merchandiser with 11 cu.ft. capacity, SS interior, self-closing door, and a digital thermostat

**Highlights:**

Commercially listed to NSF-7 standards for use in foodservice establishments

Full display all the way down to the floor

Self-closing door is ideal for busy commercial settings

Easy temperature management with a digital thermostat



Commercially listed	ETL-S listed to NSF standards and approved to UL-471 electrical standard for commercial use
Factory installed lock	Keyed lock for secure interior
Double pane tempered glass door	Heat-safe glass door offers full display all the way down to the floor
Stainless steel interior	Walls are constructed from stainless steel for added strength and easy cleanup
Recessed LED lighting	Energy efficient lighting offers full view of interior
Self-closing door	Door will automatically close when left ajar, preventing items from accidentally being exposed to ambient temperatures
Digital thermostat	Electronic controls for precise temperature management with a readout in Celsius or Fahrenheit
Professional handle	Attractive and sturdy handle in brushed stainless steel
Cantilevered chrome shelves	Adjustable shelving accommodates virtually any size with convenient cantilevered system
Open door alarm	Audible alarm will sound if the door is left ajar for over a minute

# SCR1156 Specifications:

Height	58.38"
Width	23.63"
Depth	22.88"
Capacity	11.0 cu.ft.
Ext Depth with Handle	24.0"
Interior Height 1	50.0"
Interior Width 1	20.0"
Interior Depth 1	16.5"
Comp Step Height	4.75"
Comp Step Width	20.0"
Comp Step Depth	4.75"
Shipping Weight	160.0 lbs.
Weight	141.0 lbs.
Canadian Electrical Safety	ETL-C
Amps	1.7
Voltage/Frequency	115 V AC/60 Hz
US Electrical Safety	ETL
Reversible	No
Door Swing	RHD
Shelf Quantity	4
Adjustable Shelf	true
Shelf Type	Chrome
Defrost Type	Automatic
Depth with door at 90°	45.0"
Light	true
Fan Type	Interior and Exterior
Thermostat Type	Digital
Refrigerant Type	R600a
Freon Oz	1.66
Low Side PSI	105.0
Level Legs Quantity	4
High Side PSI	270.0
Parts/Labor Warranty	1 Year
Compressor Warranty	5 Years
Sanitation	ETL-S

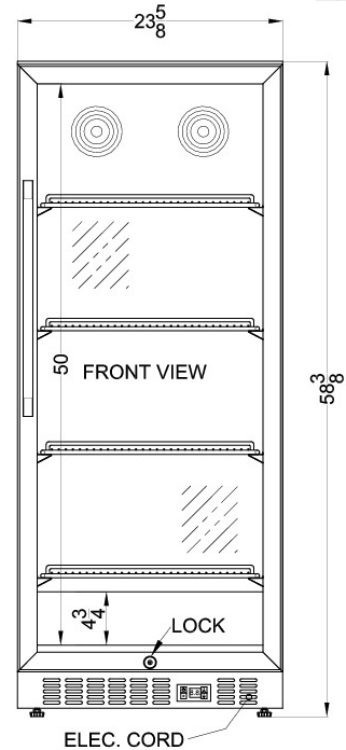
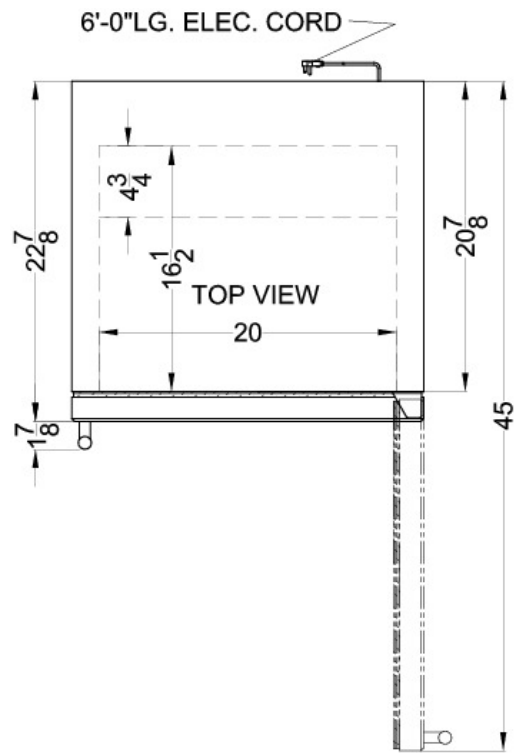

Summit Appliance Division, Felix Storch, Inc.  
 770 Garrison Ave • Bronx, NY 10474  
 Phone: 718-893-3900 • Fax: 718-842-3093  
 Email: info@summitappliance.com