

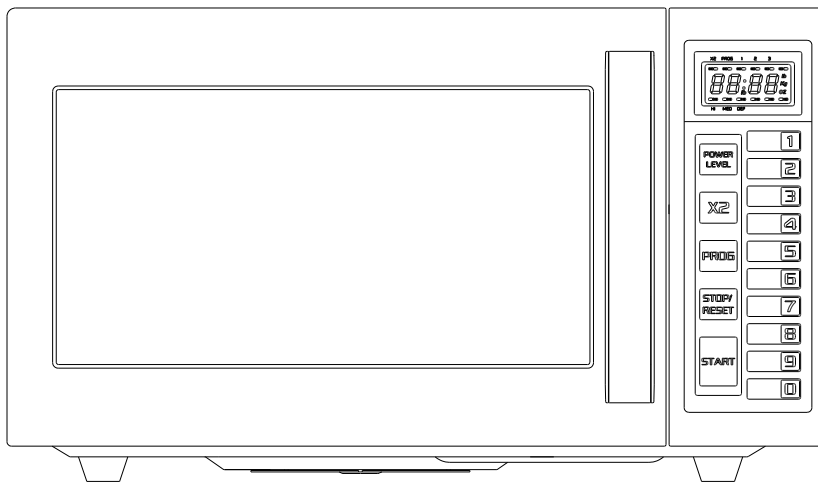

Model: SCM1000SS



Microwave Oven

User's manual

Please read these instructions carefully before installing and operating the oven.  
Record in the space below the SERIAL NO. found on the nameplate on your oven  
and retain this information for future reference.

SERIAL NO. \_\_\_\_\_

Please save sales receipt for warranty.

**Felix Storch, Inc.**

**An ISO 9001:2008 registered company**

**770 Garrison Avenue**

**Bronx, NY 10474**

**[www.summitappliance.com](http://www.summitappliance.com)**

## PRECAUTIONS TO AVOID POSSIBLE EXPOSURE TO EXCESSIVE MICROWAVE ENERGY

1. Do not attempt to operate this oven with the door-open since open-door operation can result in harmful exposure to microwave energy. It is important not to defeat or tamper with the safety interlocks.
2. Do not place any object between the oven front face and the door or allow soil or cleaner residue to accumulate on sealing surfaces.
3. Do not operate the oven if it is damaged. It is particularly important that the oven door close properly and that there is no damage to the:
  - a. Door (bent),
  - b. Hinges and latches (broken or loosened),
  - c. Door seals and sealing surfaces.
4. The oven should not be adjusted or repaired by anyone except properly qualified service personnel.

### TABLE OF CONTENTS

PRECAUTIONS TO AVOID POSSIBLE EXPOSURE TO EXCESSIVE MICROWAVE ENERGY .....	1
IMPORTANT SAFETY INSTRUCTIONS .....	2
INSTALLATION GUIDE .....	4
GROUNDING INSTRUCTIONS .....	4
UTENSILS GUIDE .....	5
COOKING TECHNIQUES .....	6
SPECIFICATIONS .....	7
DIAGRAM AND CONTROL PANEL .....	8
DIGITAL DISPLAY ACTION INDICATORS .....	8
HOW TO SET THE OVEN CONTROLS .....	9
Time and Power Level Cooking .....	9
Multiple Stage Cooking .....	9
Save a Cooking Program to a Number Key .....	9
How to Use the X2 Pad .....	10
Count of Operations .....	11
Child Lock .....	11
CLEANING AND CARE .....	12
LIMITED WARRANTY .....	13

## IMPORTANT SAFETY INSTRUCTIONS

When using electrical appliances, basic safety precautions should be followed, including the following:

**WARNING** - To reduce the risk of burns, electric shock, fire, injury to persons or exposure to excessive microwave energy:

1. Read all instructions before using the appliance.
2. Read and follow the specific "PRECAUTIONS TO AVOID POSSIBLE EXPOSURE TO EXCESSIVE MICROWAVE ENERGY" on page 1.
3. This appliance must be grounded. Connect only to properly grounded outlet. See "GROUNDING INSTRUCTIONS" on page 4.
4. Install or locate this appliance only in accordance with the provided installation instructions.
5. Some products such as whole eggs and sealed containers (for example, closed glass jars) are able to explode and should not be heated in this oven.
6. Use this appliance only for its intended use as described in this manual. Do not use corrosive chemicals or vapors in this appliance. This type of oven is specifically designed to heat, cook, or dry food.
7. As with any appliance, close supervision is necessary when used by children.
8. To reduce the risk of fire in the oven cavity:
  - a. Do not overcook food. Carefully attend appliance when paper, plastic, or other combustible materials are placed inside the oven to facilitate cooking.
  - b. Remove wire twist-ties from paper or plastic bags before placing bag in oven.
  - c. If materials inside the oven should ignite, keep oven door closed, turn oven off, and disconnect the power cord or shut off power at the fuse or circuit breaker panel.
- d. Do not use the cavity for storage purposes. Do not leave paper products, cooking utensils or food in the cavity when not in use.
9. Liquids, such as water, coffee, or tea are able to be overheated beyond the boiling point without appearing to be boiling due to surface tension of the liquid. Visible bubbling or boiling when the container is removed from the microwave oven is not always present. **THIS COULD RESULT IN VERY HOT LIQUIDS SUDDENLY BOILING OVER WHEN A SPOON OR OTHER UTENSIL IS INSERTED INTO THE LIQUID.** To reduce the risk of injury to a person:
  - a. Do not overheat the liquid.
  - b. Stir the liquid both before and halfway through heating it.
  - c. Do not use straight-sided containers with narrow necks.
  - d. After heating, allow the container to stand in the microwave oven for a short time before removing the container.
  - e. Use extreme care when inserting a spoon or other utensil into the container.
10. Do not heat oil or fat for deep-frying. It is difficult to control the temperature of oil in a microwave oven.
11. Pierce foods with heavy skins such as potatoes, whole squash, apples and chestnuts before cooking.
12. The contents of feeding bottles and baby jars should be stirred or shaken and the temperature should be checked before serving in order to avoid burns.
13. Cooking utensils may become hot because of heat transferred from the heated food. Potholders may be needed to handle the utensil.
14. Do not cover or block any openings on the appliance.
15. Do not store or use this appliance

**SAVE THESE INSTRUCTIONS**

outdoors. Do not use this product near water, for example, near a kitchen sink, in a wet basement, near a swimming pool, or similar locations.

16. Do not operate this appliance if it has a damaged cord or a plug, if it is not working properly or if it has been damaged or dropped.
17. Do not immerse cord or plug in water. Keep cord away from heated surface. Do not let cord hang over edge of table or counter.
18. Use only thermometers, which are

specifically designed for use in microwave ovens.

19. Do not operate any heating or cooking appliance beneath this appliance.
20. This appliance should be serviced only by qualified service personnel. Contact nearest authorized service facility for examination, repair, or adjustment.
21. When cleaning surfaces of door and oven that come together on closing the door, use only mild, nonabrasive soaps, or detergents applied with a sponge or soft cloth.

**SAVE THESE INSTRUCTIONS**

## INSTALLATION GUIDE

1. Make sure that all the packing materials are removed from the inside of the oven.
2. Check the oven for any damage, such as misaligned or bent door, damaged door seals and sealing surface, broken or loose door hinges and latches and dents inside the cavity or on the door. If there is any damage, do not operate the oven but contact qualified service personnel.
3. This microwave oven must be placed on a flat, stable surface to hold its weight and the heaviest food likely to be cooked in the oven.
4. Do not place the oven where heat, moisture, or high humidity are generated, or near combustible materials.
5. For correct operation, the oven must have sufficient airflow. Allow 8" of space above the oven, 4" at the back and 2" at both sides. Do not cover or block any openings on the appliance. Do not remove feet on which oven stands.
6. Make sure the power supply cord is undamaged and does not run under the oven or over any hot or sharp surface.
7. The socket must be readily accessible so that it can be easily unplugged in an emergency.

## GROUNDING INSTRUCTIONS

This appliance must be grounded. In the event of an electrical short circuit, grounding reduces risk of electric shock by providing an escape wire for the electric current.

**WARNING** Improper use of the grounding plug can result in a risk of electric shock.

Consult a qualified electrician or serviceman if the grounding instructions are not completely understood, or if doubt exists as to whether the appliance is properly grounded, and either:

1) If it is necessary to use an extension cord, use only a 3-wire extension cord that has a 3-blade grounding plug and a

3-slot receptacle that will accept the plug on the appliance. The marked rating of the extension cord should be equal to or greater than the electrical rating of the appliance, or 2) Do not use an extension cord. If the power supply cord is too short, have a qualified electrician or serviceman install an outlet near the appliance.

This appliance must be connected to a grounded, metallic, permanent wiring system, or an equipment grounding conductor should be run with the circuit conductors and connected to the equipment grounding terminal or lead on the appliance.

## ELECTRICAL REQUIREMENTS

The electrical requirements are a 120 volt 60 Hz power source, AC only, 20 amp. It is recommended that a separate circuit serving only the oven be provided. The oven is equipped with a 3-prong grounding plug. It must be plugged into a wall receptacle that is properly installed and grounded.

### Power Supply Cord

1. A short power supply cord is provided to reduce the risks resulting from becoming entangled in or tripping over a longer cord.
2. Longer cord sets or extension cords are available and may be used if care is exercised in their use.
3. If a long cord or extension cord is used:
  - a) The marked electrical rating of the cord set or extension cord should be at least as great as the electrical rating of the appliance.

- b) The extension cord must be a grounding-type 3-wire cord, and The longer cord should be arranged so that it will not drape over the counter top or table top where it can be pulled on by children or tripped over unintentionally.

### Notes:

If you have any questions about the grounding or electrical instructions, consult a qualified electrician or service person.

Neither Summit nor the dealer can accept any liability for damage to the oven or personal injury resulting from failure to observe the electrical connection procedures.

### Radio or TV Interference

Should there be any interference caused by the microwave oven to your radio or TV, check that the microwave oven is on a different circuit, relocate the radio or TV as far away from the oven as feasible or check the position and signal of the receiving antenna.

## UTENSILS GUIDE

This section lists which utensils can be used in the microwave, which ones have limited use for short periods, and which ones should not be used in the microwave.



### RECOMMENDED

**Microwave browning dish** — Use to brown the exterior of small items such as steaks, chops, or pancakes. Follow the directions provided with your browning dish.

**Microwaveable plastic wrap** — Use to retain steam. Leave a small opening for some steam to escape and avoid placing it directly on the food.

**Paper towels and napkins** — Use for short-term heating and covering; these absorb excess moisture and prevent spattering. Do not use recycled paper towels, which may contain metal and could ignite.

**Glass and glass-ceramic bowls and dishes** — Use for heating or cooking.

**Paper plates and cups** — Use for

short-term heating at low temperatures. Do not use recycled paper, which may contain metal and could ignite.

**Wax paper** — Use as a cover to prevent spattering.

**Thermometers** — Use only those labeled "Microwave Safe" and follow all directions. Check the food in several places. Conventional thermometers may be used on microwave food once the food has been removed from the oven.

## — LIMITED USE

**Aluminum foil** — Use narrow strips of foil to prevent overcooking of exposed areas. Using too much foil can damage your oven, so be careful. You should keep distance of 1 inch (2.54cm) between aluminum foil and cavity.

**Ceramic, porcelain, and stoneware**— Use these if they are labeled "Microwave Safe". If they are not labeled, test them to make sure they can be used safely.

**Plastic** — Use only if labeled "Microwave Safe". Other plastics can melt.

## ✘ Not Recommended

**Glass jars and bottles** — Regular glass is too thin to be used in a microwave. It can shatter and cause damage and injury.

**Paper bags** — These are a fire hazard, except for popcorn bags that are designed for microwave use.

**Styrofoam plates and cups** — These can melt and leave an unhealthy residue on food.

**Plastic storage and food containers** — Containers such as margarine tubs can melt in the microwave.

**Metal utensils** — These can damage your oven. Remove all metal before cooking.

### Note:

Should you wish to check if a dish is safe for microwaving, place the empty dish in the oven and microwave on HIGH for 30 seconds. A dish which becomes very hot should not be used.

## COOKING TECHNIQUES

Your microwave makes cooking easier than conventional cooking, provided you keep these considerations in mind:

### STIRRING

Stir foods such as casseroles and vegetables while cooking to distribute heat evenly. Food at the outside of the dish absorbs more energy and heats more quickly, so stir from the outside to the center. The oven will turn off when

you open the door to stir your food.

### ARRANGEMENT

Arrange unevenly shaped foods, such as chicken pieces or chops, with the thicker, meatier parts toward the outside of the heating platter where they receive more microwave energy. To prevent overcooking, place delicate areas, such as asparagus tips, toward the center of the platter.

## **SHIELDING**

Shield food with narrow strips of aluminum foil to prevent overcooking. Areas that need shielding include poultry wing tips, the ends of poultry legs, and corners of square baking dishes. Use only small amounts of aluminum foil. Larger amounts can damage your oven.

## **TURNING**

Turn foods over midway through cooking to expose all parts to microwave energy. This is especially important with large foods such as roasts.

## **STANDING**

Foods cooked in the microwave build up internal heat and continue to cook for a few minutes after heating stops. Let

foods stand to complete cooking, especially foods such as cakes and whole vegetables. Roasts need this time to complete cooking in the center without overcooking the outer areas. All liquids, such as soup or hot chocolate, should be shaken or stirred when cooking is complete. Let liquids stand a moment before serving. When heating baby food, stir well at removal and test the temperature before serving.

## **ADDING MOISTURE**

Microwave energy is attracted to water molecules. Food that is uneven in moisture content should be covered or allowed to stand so that the heat disperses evenly. Add a small amount of water to dry food to help it cook.

# **SPECIFICATIONS**

Power Consumption:	120V~60Hz, 1450W (MICROWAVE)
Output:	1000W
Operation Frequency:	2450MHz
Outside Dimensions(HxWxD):	12.3×20.5×17.9 in.
Oven Cavity Dimensions(HxWxD):	8.4×13.2×14.3 in.
Oven Capacity:	0.88cu.ft
Net Weight:	Approx. 39lb.



# DIAGRAM AND CONTROL PANEL

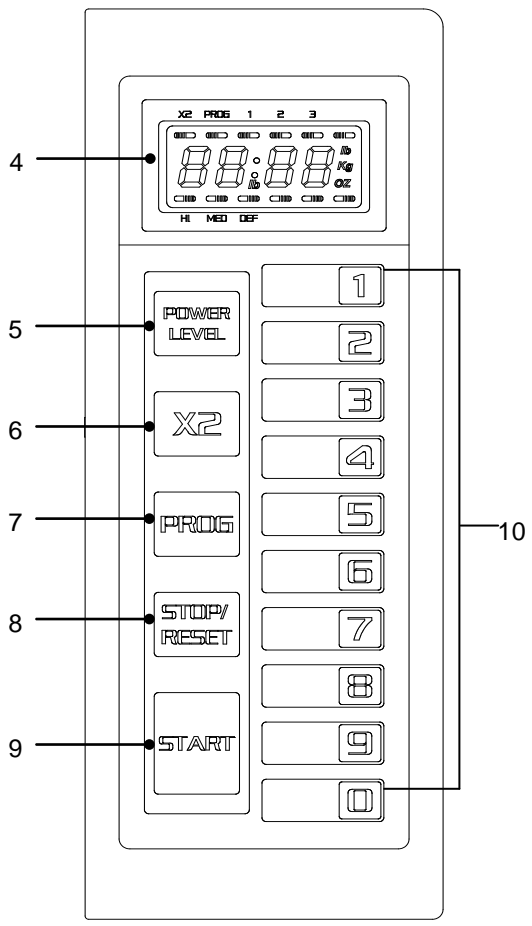
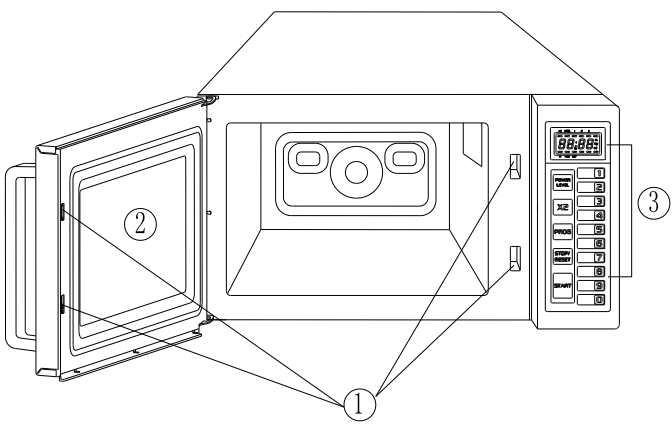

- 1. Door Safety Lock System
- 2. Oven Window
- 3. Control Panel
- 4. Digital display window
- 5. Power level pad
- 6. X2 pad
- 7. Program pad
- 8. Stop/Reset pad
- 9. Start pad
- 10. Number/Memory pads

# DIGITAL DISPLAY ACTION INDICATORS

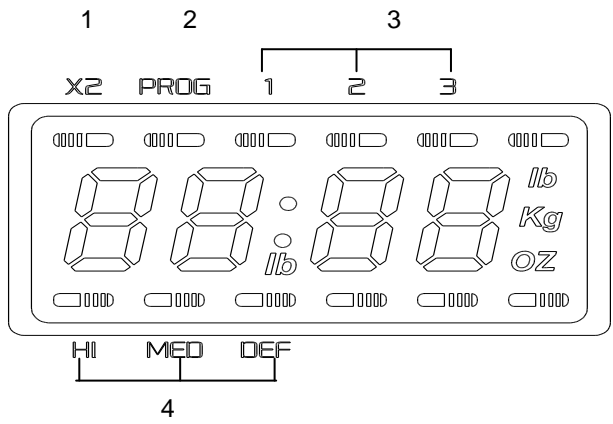

- 1. X2 indicating cooking in X2 feature.
- 2. PROG indicating programming a cooking
- 3. Numbers indicating the cooking stage
- 4. Indicating power level used in cooking

# HOW TO SET THE OVEN CONTROLS

## TIME AND POWER LEVEL COOKING

To set a cooking program.

Select a cooking power level and then use the number pads to set cooking time before touching the START pad. The longest cooking time is 99 minutes 99 seconds.

Touch POWER LEVEL	Power Description
Once	HI
Twice	MED
Thrice	DEF

For a single stage cooking, here is an example to set cooking power at full (HI) and cook for 3 minutes:

1. Touch POWER LEVEL pad once.
2. Touch number pads 3, 0, 0.
3. Touch START pad.

## MULTIPLE STAGE COOKING

Food may require different periods/stages of cooking with different power levels and cooking times. You can set up to 3 stages cooking manually.

### For Stage 1 cooking

Set the first stage cooking according to the steps specified above.

### For Stage 2 cooking

Set the second stage cooking programming different power level and time; for example, power set at medium; cooking time 5 minutes.

To set the second stage cooking of medium power and 5 minutes time, after the above steps 1,2, do not touch the START pad, but do the following :

1. Touch POWER LEVEL pad twice
2. Touch number pads 5,0,0.
3. Touch START pad.

## SAVE A COOKING PROGRAM TO A NUMBER KEY

If you have a frequently used cooking program, you can save it to a number key and conveniently activate it by touching the number key and then START pad.

Each of the number keys is pre-set with a cooking program. In waiting mode, touch any of the ten number pads and you will be selecting a cooking program. Then press the START pad to start the preset program.

The following are default settings for each of the number keys

Number/Memory Pads	1	2	3	4	5	6	7	8	9	0
Preset Cooking Time	:10	:20	:30	:45	1:00	1:30	2:00	2:30	3:00	3:30

The user is free to reset the cooking program stored under each of the ten number keys anytime. In order to set a cooking program, which may contain up to 3 stages of consecutive cooking periods with different power levels, and to designate a number key for this program, see the example below:

To set medium power cooking for 8 min. and save it to number pad 5:

1. Touch PROG once.
2. Press number pad 5.
3. Press POWER LEVEL twice to select MED.
4. Touch number pads 8, 0, 0.
5. Press PROG to save.

You can set a two- or three-stage cooking program by repeating the steps 3-4 once or twice. When finished, press STOP/RESET to return to waiting mode.

Note: If you want the oven to start immediately after touching any of the number keys instead of after touching the START pad, press and hold down STOP/RESET for 5 sec until “P L” appears on the display. Now you don’t need to press the START pad after selecting a cooking program by touching any of the number keys.

### HOW TO USE THE X2 PAD

More cooking programs can be stored under the number keys by using the X2 function.

In waiting mode, press X2, any of the number keys, and the START pad, you can recall a preset cooking program as follows:

Number/Memory Pads	1	2	3	4	5	6	7	8	9	0
Preset Cooking Time	:20	:40	1:00	1:30	2:00	3:00	4:00	5:00	6:00	7:00

X2 function can only program one-stage cooking. After setting is completed, press STOP/RESET to return to waiting mode. The oven will start after you touch X2, any of the number keys and then the START pad.

For example, to use the X2 function, and save a program of full power and 3 minutes cooking to number pad 8.

1. Touch PROG once.
2. Touch X2 pad once.
3. Press number pad 8.
4. Press POWER LEVEL once.
5. Touch number pads 3, 0, 0.
6. Press PROG to save.

Note: If you want the oven to start immediately after touching any of the number keys instead of after touching the START pad, press and hold down STOP/RESET for 5 sec until "P L" appears on the display; now you don't need to press the START pad after selecting a cooking program by touching any of the number keys.

## **COUNT OF OPERATIONS**

---

You can read the count of how many times the oven has been used. To do this,

1. In waiting mode, press and hold down STOP/RESET.
2. Touch the POWER LEVEL pad. The number on the display shows how many times the oven has been used.

This function is for the user to analyze the usage of the oven and the traffic flow at a particular location where the oven is being used commercially.

## **CHILD LOCK**

---

In waiting mode, press and hold PROG for 5 seconds. The oven is locked.

To release the child lock,

Press and hold PROG for 5 seconds. The oven returns to normal.

## CLEANING AND CARE

1. Turn off the oven and remove the power plug from the wall socket before cleaning.
2. Keep the inside of the oven clean. When food splatters or spilled liquids adhere to oven walls, wipe with a damp cloth. Mild detergent may be used if the oven gets very dirty. Avoid the use of spray and other harsh cleaners as they may stain, streak or dull the door surface.
3. The outside surfaces should be cleaned with a damp cloth. To prevent damage to the operating parts inside the oven, water should not be allowed to seep into the ventilation openings.
4. Wipe the window on both sides with a damp cloth to remove any spills or splatters.
5. Do not allow the control panel to become wet. Clean with a soft, damp cloth. When cleaning the control panel, leave oven door open to prevent oven from accidentally turning on.
6. If condensation accumulates inside or around the outside of the oven door, wipe with a soft cloth. This may occur when the microwave oven is operated under high humidity conditions. In such case, it is normal.
7. The oven floor should be cleaned regularly. Simply wipe the bottom surface of the oven with mild detergent.
8. Remove odors from your oven by combining a cup of water with the juice and skin of one lemon in a deep microwaveable bowl. Microwave for 5 minutes. Wipe thoroughly and dry with a soft cloth.
9. When it becomes necessary to replace the oven light, please consult a dealer to have it replaced.
10. The oven should be cleaned regularly and any food deposits removed. Failure to maintain the oven in a clean condition could lead to deterioration of the surface that could adversely affect the life of the appliance and possibly result in a hazardous situation.
11. Please do not dispose of this appliance in the domestic rubbish bin. It should be sent to the particular disposal center provided by your municipality.

# LIMITED WARRANTY

## 90-DAY LIMITED WARRANTY

Within the 48 contiguous United States, for 90 days from the date of purchase, when this appliance is operated and maintained according to instructions attached to or furnished with the product, warrantor will pay for factory-specified parts and repair labor to correct defects in materials or workmanship. Service must be provided by a designated service company. Outside the 48 states, all parts are warranted for 90 days from manufacturing defects. Plastic parts, shelves and cabinets are warranted to be manufactured to commercially acceptable standards, and are not covered from damage during handling or breakage.

### *ITEMS WARRANTOR WILL NOT PAY FOR:*

1. Service calls to correct the installation of your appliance, to instruct you how to use your appliance, to replace or repair fuses or to correct wiring or plumbing.
2. Service calls to repair or replace appliance light bulbs or broken shelves. Consumable parts (such as filters) are excluded from warranty coverage.
3. Damage resulting from accident, alteration, misuse, abuse, fire, flood, acts of God, improper installation, installation not in accordance with electrical or plumbing codes, or use of products not approved by warrantor.
4. Replacement parts or repair labor costs for units operated outside the United States.
5. Repairs to parts or systems resulting from unauthorized modifications made to the appliance.
6. The removal and reinstallation of your appliance if it is installed in an inaccessible location or is not installed in accordance with published installation instructions.

### DISCLAIMER OF IMPLIED WARRANTIES; LIMITATION OF REMEDIES

CUSTOMER'S SOLE AND EXCLUSIVE REMEDY UNDER THIS LIMITED WARRANTY SHALL BE PRODUCT REPAIR AS PROVIDED HEREIN. IMPLIED WARRANTIES, INCLUDING WARRANTIES OF MERCHANTABILITY OR FITNESS FOR A PARTICULAR PURPOSE, ARE LIMITED TO 90 DAYS. WARRANTOR SHALL NOT BE LIABLE FOR INCIDENTAL OR CONSEQUENTIAL DAMAGES. SOME STATES DO NOT ALLOW THE EXCLUSION OR LIMITATION OF INCIDENTAL OR CONSEQUENTIAL DAMAGES, OR LIMITATIONS ON THE DURATION OF IMPLIED WARRANTIES OF MERCHANTABILITY OR FITNESS, SO THESE EXCLUSIONS OR LIMITATIONS MAY NOT APPLY TO YOU. THIS WARRANTY GIVES YOU SPECIFIC LEGAL RIGHTS AND YOU MAY ALSO HAVE OTHER RIGHTS, WHICH VARY FROM STATE TO STATE.

**WARNING!** This product may contain chemicals known to the state of California to cause cancer or birth defects or other reproductive harm. For more information, visit: [www.summitappliance.com/prop65](http://www.summitappliance.com/prop65)

Chemicals known by the manufacturer to be present in this product in concentrations higher than threshold limits: NONE.

**FELIX STORCH, INC.**  
**770 Garrison Avenue**  
**Bronx, NY 10474**  
**Phone: (718) 893-3900**  
**Fax: (844) 478-8799**  
**[www.summitappliance.com](http://www.summitappliance.com)**



For parts and accessory ordering,  
troubleshooting and helpful hints, visit:  
**[www.summitappliance.com/support](http://www.summitappliance.com/support)**

Printed in China