

Model XRA Hand Dryer



Recessed A.D.A. Compliant Automatic Hand Dryer

WORLD DRYER

World Model XRA hand dryer is an ADA compliant automatic hand dryer with longest motor life and the best washroom solutions for all high traffic applications.

Product Benefits

- ADA compliant
- Automatic operation
- Longest life of all dryers
- Lowest sound level
- Durable and vandal resistant
- Classic style design

Design Features

Dryer

- Activated by infrared sensor
- Automatic drying cycle
- Incorporates a 2100 (optional 1500) watt Nichrome wire heating element
Protected by an automatic-resetting, thermal cutoff
- Provides a 70° F temperature rise
- IPX1 ingress protection

Motor

- Thermally-protected, universal brush-type motor operating at 7,500 RPM
- Delivering 154 CFM air flow at a velocity of 7,300 LFM

Materials

- Cover material: Cast Iron with porcelain enamel finish. Optional 304 stainless steel
- The wall-mounted base is constructed of die-cast aluminum
- The nozzle is constructed of die-cast zinc alloy finished in bright chrome



Architecture & Engineering Specifications

World Dryer Model XRA hand dryers shall include a cover made of 1/4" thick cast iron with porcelain enamel finish. Optional 14GA, Brushed 304S.S. Cover. Motor shall be universal type, 1/10 HP at 7500 RPM. Dryers shall deliver 154 cubic feet per minute of air volume (7300 LFM). Infrared sensor detect hands, initiates and terminates drying cycle. High-tech sensor control to provide 1,000,000 dry cycles. Recessed units use a 16-gauge steel wall mounting box. Hand dryers shall be listed under reexamination service of Underwriters Laboratories, Inc.

Model XRA Product Specifications

Electrical

	115 V	115 V	208 - 230 V	220 - 240 V	277 V
Amps	20	15	10	10	8.5
Watts	2300	1725	2300	2300	2300
Hz	60	60	60	50	60

Stock #	Cover Finish	Cover Material	Electrical	Unit Weight	Unit Size (HxWxD) inch/mm	Shipping Size (HxWxD) inch/mm
XRA5-974	White	Cast Iron	115 V, 20 Amp	35 lbs/15.8 kgs	13.8" x 13.1" x 4" 351 x 333 x 102	15" x 15" x 11.25 381 x 381 x 286
XRA52-974	White	Cast Iron	115 V, 15 Amp	35 lbs/15.8 kgs	13.8" x 13.1" x 4" 351 x 333 x 102	15" x 15" x 11.25 381 x 381 x 286
XRA54-974	White	Cast Iron	208 - 230V	35 lbs/15.8 kgs	13.8" x 13.1" x 4" 351 x 333 x 102	15" x 15" x 11.25 381 x 381 x 286
XRA548-974	White	Cast Iron	220 - 240 V	35 lbs/15.8 kgs	13.8" x 13.1" x 4" 351 x 333 x 102	15" x 15" x 11.25 381 x 381 x 286
XRA57-974	White	Cast Iron	277 V	35 lbs/15.8 kgs	13.8" x 13.1" x 4" 351 x 333 x 102	15" x 15" x 11.25 381 x 381 x 286
DXRA5-973	Brushed	Stainless Steel	115 V, 20 Amp	28 lbs/12.7 kgs	13.8" x 13.1" x 4" 351 x 333 x 102	15" x 15" x 11.25 381 x 381 x 286
DXRA52-973	Brushed	Stainless Steel	115 V, 15 Amp	28 lbs/12.7 kgs	13.8" x 13.1" x 4" 351 x 333 x 102	15" x 15" x 11.25 381 x 381 x 286
DXRA54-973	Brushed	Stainless Steel	208 - 230V	28 lbs/12.7 kgs	13.8" x 13.1" x 4" 351 x 333 x 102	15" x 15" x 11.25 381 x 381 x 286
DXRA548-973	Brushed	Stainless Steel	220 - 240 V	28 lbs/12.7 kgs	13.8" x 13.1" x 4" 351 x 333 x 102	15" x 15" x 11.25 381 x 381 x 286
DXRA57-973	Brushed	Stainless Steel	277 V	28 lbs/12.7 kgs	13.8" x 13.1" x 4" 351 x 333 x 102	15" x 15" x 11.25 381 x 381 x 286

Model XRA Hand Dryer



Recessed A.D.A. Compliant Automatic Hand Dryer

WORLD DRYER

World Model XRA hand dryer is an ADA compliant automatic hand dryer with longest motor life and the best washroom solutions for all high traffic applications.

Product Benefits

- ADA compliant
- Automatic operation
- Longest life of all dryers
- Lowest sound level
- Durable and vandal resistant
- Classic style design

Design Features

Dryer

- Activated by infrared sensor
- Automatic drying cycle
- Incorporates a 2100 (optional 1500) watt Nichrome wire heating element Protected by an automatic-resetting, thermal cutoff
- Provides a 70° F temperature rise
- IPX1 ingress protection

Motor

- Thermally-protected, universal brush-type motor operating at 7,500 RPM
- Delivering 154 CFM air flow at a velocity of 7,300 LFM

Materials

- Cover material: Cast Iron with porcelain enamel finish. Optional 304 stainless steel
- The wall-mounted base is constructed of die-cast aluminum
- The nozzle is constructed of die-cast zinc alloy finished in bright chrome



Architecture & Engineering Specifications

World Dryer Model XRA hand dryers shall include a cover made of 1/4" thick cast iron with porcelain enamel finish. Optional 14GA, Brushed 304S.S. Cover. Motor shall be universal type, 1/10 HP at 7500 RPM. Dryers shall deliver 154 cubic feet per minute of air volume (7300 LFM). Infrared sensor detect hands, initiates and terminates drying cycle. High-tech sensor control to provide 1,000,000 dry cycles. Recessed units use a 16-gauge steel wall mounting box. Hand dryers shall be listed under reexamination service of Underwriters Laboratories, Inc.

Model XRA Product Specifications

Electrical

	115 V	115 V	208 - 230 V	220 - 240 V	277 V
Amps	20	15	10	10	8.5
Watts	2300	1725	2300	2300	2300
Hz	60	60	60	50	60

Stock #	Cover Finish	Cover Material	Electrical	Unit Weight	Unit Size (HxWxD) inch/mm	Shipping Size (HxWxD) inch/mm
XRA5-974	White	Cast Iron	115 V, 20 Amp	35 lbs/15.8 kgs	13.8" x 13.1" x 4" 351 x 333 x 102	15" x 15" x 11.25 381 x 381 x 286
XRA52-974	White	Cast Iron	115 V, 15 Amp	35 lbs/15.8 kgs	13.8" x 13.1" x 4" 351 x 333 x 102	15" x 15" x 11.25 381 x 381 x 286
XRA54-974	White	Cast Iron	208 - 230V	35 lbs/15.8 kgs	13.8" x 13.1" x 4" 351 x 333 x 102	15" x 15" x 11.25 381 x 381 x 286
XRA548-974	White	Cast Iron	220 - 240 V	35 lbs/15.8 kgs	13.8" x 13.1" x 4" 351 x 333 x 102	15" x 15" x 11.25 381 x 381 x 286
XRA57-974	White	Cast Iron	277 V	35 lbs/15.8 kgs	13.8" x 13.1" x 4" 351 x 333 x 102	15" x 15" x 11.25 381 x 381 x 286
DXRA5-973	Brushed	Stainless Steel	115 V, 20 Amp	28 lbs/12.7 kgs	13.8" x 13.1" x 4" 351 x 333 x 102	15" x 15" x 11.25 381 x 381 x 286
DXRA52-973	Brushed	Stainless Steel	115 V, 15 Amp	28 lbs/12.7 kgs	13.8" x 13.1" x 4" 351 x 333 x 102	15" x 15" x 11.25 381 x 381 x 286
DXRA54-973	Brushed	Stainless Steel	208 - 230V	28 lbs/12.7 kgs	13.8" x 13.1" x 4" 351 x 333 x 102	15" x 15" x 11.25 381 x 381 x 286
DXRA548-973	Brushed	Stainless Steel	220 - 240 V	28 lbs/12.7 kgs	13.8" x 13.1" x 4" 351 x 333 x 102	15" x 15" x 11.25 381 x 381 x 286
DXRA57-973	Brushed	Stainless Steel	277 V	28 lbs/12.7 kgs	13.8" x 13.1" x 4" 351 x 333 x 102	15" x 15" x 11.25 381 x 381 x 286

Recess Mounted

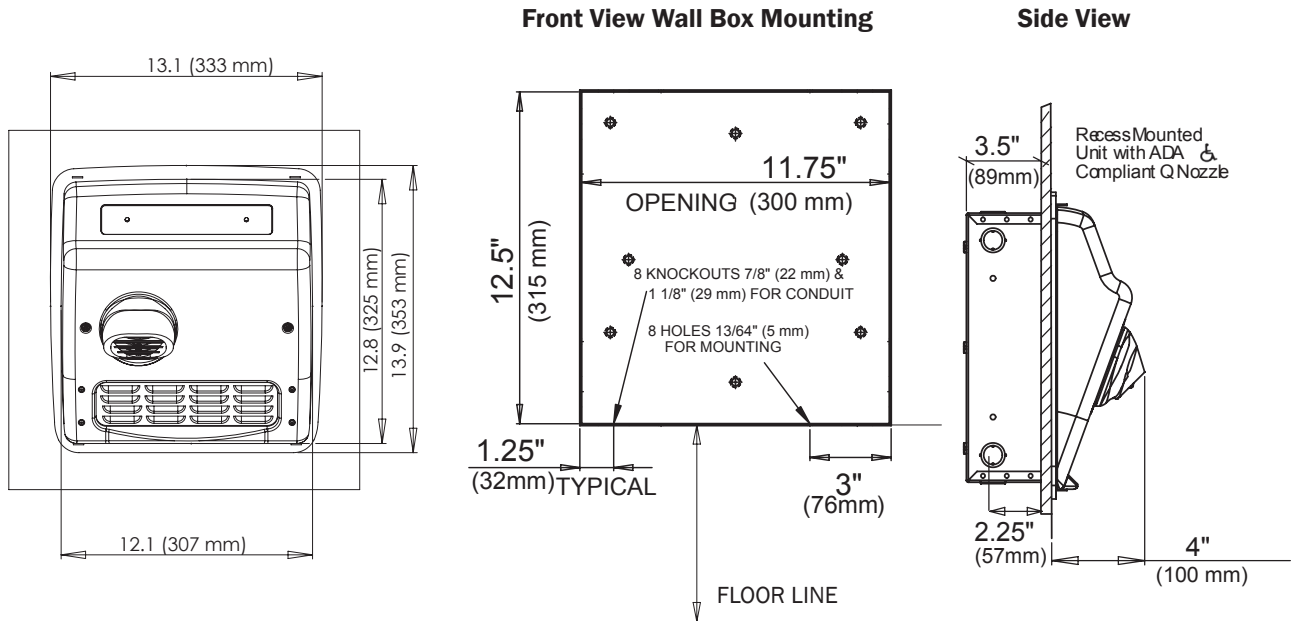

Placement Instruction

- Hand dryers should be spaced at least 2' apart, near but not over the wash basin
- Automatic dryers should be located more than 18" above or away from any reflective surface that may interfere with the sensor operation.
- In congested areas, dryers should be located to create a flow from wash basin to dryer to exit
- Dryer Quantity Recommendation:
Average Traffic: 1 dryer per 2 wash basins
Heavy Traffic: 1 dryer per wash basin
Industrial 54" Circular wash fountains: 4 dryers per sink
- Recommended mounting heights from floor to dryer bottom edge

Men's washrooms	42" (107 cm)
Women's washrooms	40" (102 cm)
Children's washrooms, ages 4-7	28" (71 cm)
Children's washrooms, ages 7-10	32" (81 cm)
Children's washrooms, ages 10-13	36" (91 cm)
Children's washrooms, ages 13-17	40" (102 cm)
Handicap Mounting Height	34" (86 cm)

Measured from floor to the bottom of the unit.

Installation Guide

- Model XRA hand dryers require a dedicated 20 AMP circuit and must be properly grounded
- GFI circuit protection is recommended.
- One side of dryer should be mounted to a stud

Certification Approved



IPX1



Warranty



5 year on sensor
3 year on motor brushes

10 year limited warranty



5700 McDermott Drive
Berkeley, IL 60163 U.S.A.
800-323-0701
www.worlddryer.com

92-MT041 Rev02

Recess Mounted

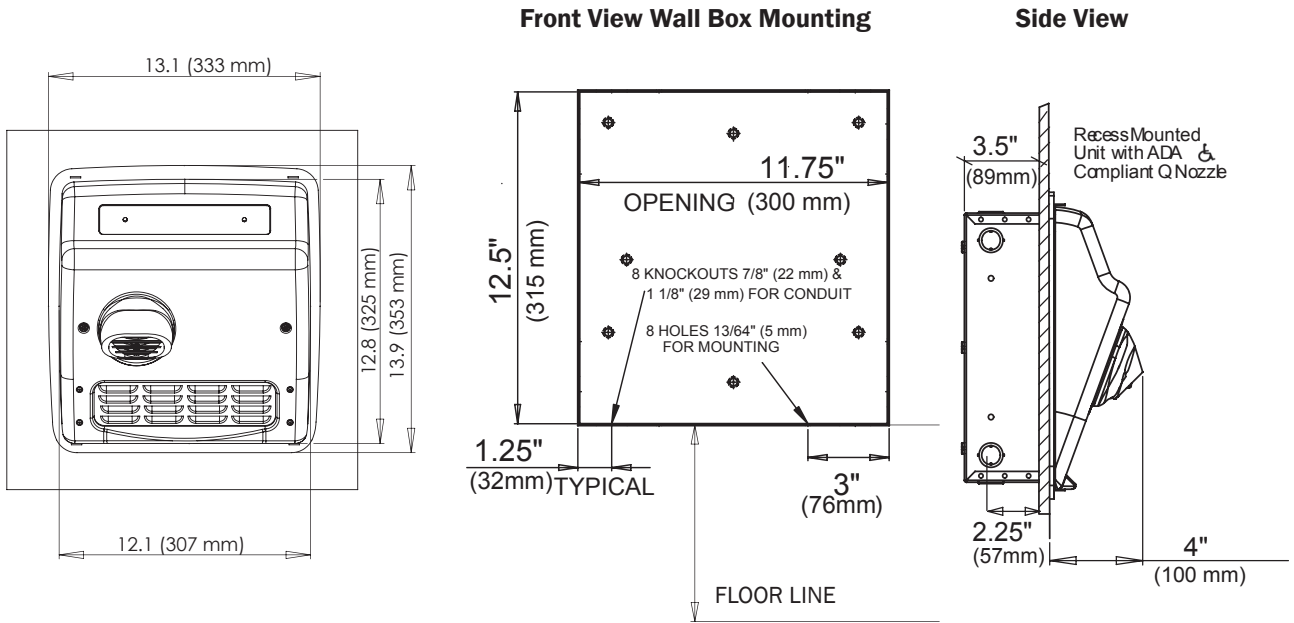

Placement Instruction

- Hand dryers should be spaced at least 2' apart, near but not over the wash basin
- Automatic dryers should be located more than 18" above or away from any reflective surface that may interfere with the sensor operation.
- In congested areas, dryers should be located to create a flow from wash basin to dryer to exit
- Dryer Quantity Recommendation:
Average Traffic: 1 dryer per 2 wash basins
Heavy Traffic: 1 dryer per wash basin
Industrial 54" Circular wash fountains: 4 dryers per sink
- Recommended mounting heights from floor to dryer bottom edge

Men's washrooms	42" (107 cm)
Women's washrooms	40" (102 cm)
Children's washrooms, ages 4-7	28" (71 cm)
Children's washrooms, ages 7-10	32" (81 cm)
Children's washrooms, ages 10-13	36" (91 cm)
Children's washrooms, ages 13-17	40" (102 cm)
Handicap Mounting Height	34" (86 cm)

Measured from floor to the bottom of the unit.

Installation Guide

- Model XRA hand dryers require a dedicated 20 AMP circuit and must be properly grounded
- GFI circuit protection is recommended.
- One side of dryer should be mounted to a stud

Certification Approved



IPX1



Warranty



5 year on sensor
3 year on motor brushes

10 year limited warranty



5700 McDermott Drive
Berkeley, IL 60163 U.S.A.
800-323-0701
www.worlddryer.com

92-MT041 Rev02