

NON-INSULATED DELUXE PROOF/HOT CABINET MODEL 121-PH-1818D

FEATURES AND BENEFITS:

- Non-Insulated versatile proof/hot cabinet. Use as an all purpose proofer or a moving air proofer for delicate products, as well as a holding cabinet to keep prepared foods at serving temperatures.
- Powerful, yet efficient, heating system maintains the right combination of heat and humidity to properly proof or hold products.
- 1920 Watts of heat holds foods at up to 180°F (82°C); proofing with 960 Watts allows for temperatures of 80°F (26.5°C) to 95°F (35°C), with relative humidity of 95%.
- Body constructed of non-corrosive, Hi-Tensile aluminum for strength and ease of mobility.
- Field reversible Lexan door allows for viewing products. Perimeter door gasket minimizes heat loss. Standard with right hand hinging; left hand hinging available upon request.
- Magnetic latch secures door during transport.
- Wire angle ledge pan supports hold 18" x 26" or 12" x 20" pans on 3" centers.
- Controls accessible without opening door; allows adjustment without interrupting process.
- Slanted control panel has easy-to-read thermometer; entire power assembly removable for cleaning and maintenance.
- Integral drip trough on front keeps traffic area dry, safer.
- Heavy duty 5" swivel casters, two with brakes. Provides mobility when fully loaded.



121-PH-1818D



ACCESSORIES and OPTIONS (Available at extra cost):

- Dutch Doors
- Corner Bumpers
- Perimeter Bumper (three sided)
- Various Caster Options
- Digital Thermometer
- Push Handle
- 208 or 240 Volt Service

See page D-4 for accessory details.

121-PH-1818D

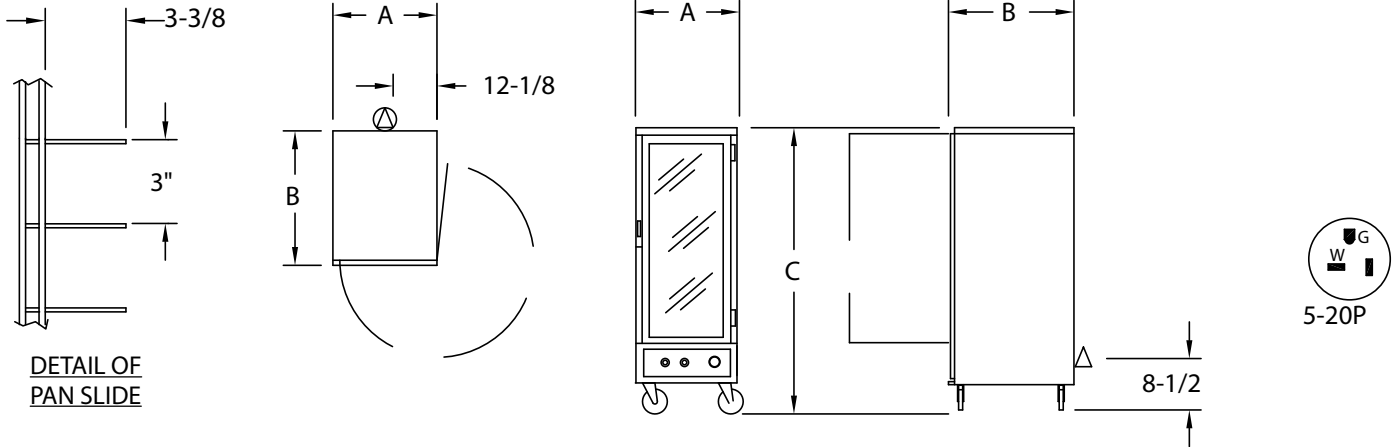

CRES COR MODEL NO.	PAN			DIM "A"	DIM "B"	DIM "C"	INSIDE DIMENSIONS			WEIGHT ACT.	
	CAP	SIZE		WIDTH	DEPTH	HEIGHT	WIDTH	DEPTH	HEIGHT		
121-PH-1818D	18	18 x 26	IN	24-1/4	32	69-3/4	21-1/4	28-1/4	54-3/8	LBS	160
		460 x 660	MM	620	815	1775	540	718	1385	KG	73
	36	12 x 20	IN								
		305 x 510	MM								

When ordering bumpers, add 2" to overall dimensions.

ALL ALUMINUM CONSTRUCTION IS RIVETED, WELDED AND FINISHED.

CABINET:

- Top: One piece .063 aluminum; riveted to sides and back.
- Side panels: Formed .063 aluminum; fastened to base and top.
- Back panel: .063 aluminum; fastened to base and top.
- Air tunnel: .063 aluminum; lift-out type, mounted on back panel.

BASE:

- One piece construction, .125 aluminum.
- Drip trough: Formed 18 ga. 304 stainless steel mounted to front of base; removable drip pan.
- Casters: 5" dia., swivel, modulus tires, 1-1/4 wide, load cap. 250 lbs. each, temp. range -45°/+180°F. Delrin bearings. Front casters equipped with brakes.

DOOR:

- Field reversible.
- Frame: Black powder coated extruded aluminum, 13/16 x 1-11/16; fastened together.
- Panel: 3/16 clear Lexan, fitted into door frame.
- Latch: Magnetic type with pull handle.
- Hinges (2): Chrome plated steel.
- Gasket: Perimeter type, Santoprene rubber.

PAN SLIDES:

- Rack inserts (lift-out): Nickel chrome plated wire (.250 dia.); (18) angles on 3" centers

PROOF/HOT UNIT COMPONENTS:

- Removable bottom mount proof/hot unit.
- Body: Formed .063 aluminum with black control panel.
- Thermostat (holding): Mechanical, room ambient to 180°F. (82°C.).
- Thermostat (humidity): Mechanical, room ambient to 95%.

PROOF/HOT UNIT COMPONENTS (CONT.):

- Pilot lights.
- Switches (2): Rocker type.
- Power cord: Permanent, 6 ft., 12/3 ga. with molded plug.
- Heaters (2): 960 Watts for holding.
- Blower motor.
- Thermometer.
- Water pan: 3-1/2 quart; 22 ga. 304 stainless steel with 960 Watt heater for humidity.

POWER REQUIREMENTS:

- 1920 Watts, 120 Volts, 60 Hz., single phase, 16 Amps., 20 Amp. service.

SHORT FORM SPECIFICATIONS

Cres Cor Proof/Hot Cabinet Model 121-PH-1818D. Formed and welded .063 aluminum top, .125 aluminum base. Wire angles for (18) 18" x 26" or (36) 12" x 20" pans on 3" centers. Field reversible Lexan door with magnetic pull latch. Removable 1920 Watt, 120 Volt power unit; adjustable heat and humidity. Controls accessible without opening door. 5" swivel modulus casters, Delrin bearings. Load capacity 250 lbs. each. 1-Year Parts / 90-Day Labor warranty. Provide the following accessories: _____ CSA-US, CSA-C, CSA to NSF4 listed.



5925 Heisley Road • Mentor, OH 44060-1833
 Phone: 877/CRESCOR • Fax: 440/350-7267
 www.crescor.com

© Crescent Metal Products, Inc. 2011 All rights reserved.

In line with its policy to continually improve its products, CRES COR reserves the right to change materials and specifications without notice.

Litho in U.S.A.