

HotCube³™ TRI-POWERED INSULATED INDOOR/OUTDOOR HOT CABINET MODEL HC-UA-11

FEATURES AND BENEFITS:

- Industry's first hybrid heated hot cabinet allowing you to hold food safe indoors or out with or without a cord!
- Allows you the flexibility to use indoors with standard 120 Volt electric, then unplug and use outdoors via new propane fuel hybrid heat system.
- Fully insulated 3/4 size holding cabinet keeps prepared foods at proper serving temperatures.
- Powerful, yet efficient, 1500 Watt heating system maintains the right temperature to properly hold products utilizing electric or 8700 BTU's of propane fuel. Heats up to 200°F (93°C).
- Battery indicator shows current battery status. Optional solar panel charges battery for optimum control efficiency when no electric capabilities are available.
- Utilizes standard 1 lb. propane tanks for up to 8 hours of hold time. Recessed well provided for spare 1 lb. tank canister. Easily converts to 20 lb. tank system with 20 lb. hose adapter accessory.
- Easy visual sight glass to see propane flame. Audible and visual alarms warns of flame out conditions.
- Internal frame in body maintains structural rigidity. Standard with perimeter bumper to protect cabinet body and walls from damage.
- Eleven sets of locking transport angles accommodate a large variety of pan sizes. Provides capacity up to 22 12 x 20 steam table pans.
- Heavy duty 8" all-terrain, never-flat swivel casters, two with brakes. Rear casters are fixed to provide mobility when fully loaded, and stability during transport even in tough outdoor conditions.
- Smooth interior coved corners prevent food particle/grease buildup.
- Customize the powder coating with your colors, add your logos or both!

Before use in altitudes greater than 7,000 feet, consult factory.



HC-UA-11



ACCESSORIES and OPTIONS (Available at extra cost):

- Solar Panel
- 20 lb. Hose Adapter
- Door Window
- Customized Logos/Powder Coating
- 6" Hi-Modulus Casters

See page B-30 for accessory details.

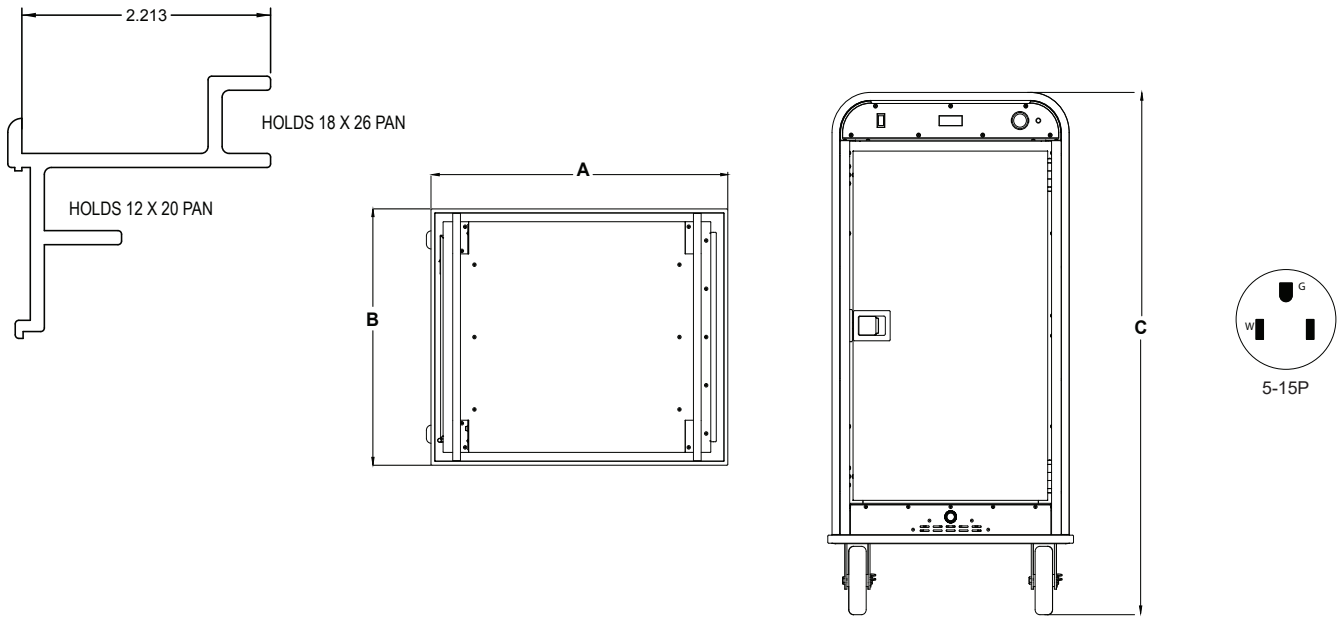

CRES COR MODEL NO.	PAN			DIM "A"	DIM "B"	DIM "C"	INSIDE DIMENSIONS				WEIGHT ACT.
	CAP/ANGLES	SIZE		WIDTH	DEPTH	HEIGHT	WIDTH	DEPTH	HEIGHT		
HC-UA-11	11 SETS	SEE NOTE BELOW	IN	31-7/8	38-1/2	65	22	27	42	LBS	468
			MM	810	980	1650	560	690	1070	KG	212

NOTE: Pan sizes 18" x 26" (460 x 660) Bun Pans, 12" x 20" (305 x 510) Steam Table Pans.

CABINET:

- Inner body: 22 ga. stainless steel.
- Outer body: .063 aluminum, powder coated red.
- Reinforcement: Internal framework of 20 ga. stainless steel.
- Insulation: Fiberglass, thermal conductivity (K factor) is .23 at 75°F. 1-1/2" in door, back, top and sidewalls.
- Push/pull handles (2) powder coated black.
- Interior coved corners.
- 1-1/4" Sight glass for flame detection.

BASE:

- One piece construction, .060 stainless steel.
- Casters: 8" dia., (2) swivel (2) fixed, pneumatic, load cap. 310 lbs. each, Double ball bearings. Front casters equipped with brakes.

DOOR:

- Formed 22 ga. stainless steel.
- Latches: Polished stainless steel, slam type; mounted inboard.
- Gasket: Perimeter type.

TRANSPORT PAN SLIDES:

- Extruded aluminum; mounted on locking lift-off posts.
- Spaced on 3" centers.



Scan QR code to view Spec Sheet, Operating Manual, Wiring Diagram or to call Customer Service.

If you need a QR reader visit your App Store on your Smartphone or Tablet.



5925 Heisley Road • Mentor, OH 44060-1833
 Phone: 877/CRESCOR • Fax: 440/350-7267
 www.crescor.com

© Crescent Metal Products, Inc. 2019 All rights reserved.

HOT UNIT COMPONENTS:

- Propane powered heating system.
- Burner: 8700 BTU's
- Switch: Selector Gas / Off / Electric.
- Audible and visual alarm.
- Battery indicator.
- Power cord: Permanent, 10 ft., 14/3 ga.
- Heaters: 1500 Watts.
- Thermostat: Digital, 140°F to 200°F.

POWER REQUIREMENTS:

- 1500 Watts, 120 Volts, 60 Hz., single phase, 10 Amps., 15 Amp. service.
- Battery system 12 Volt rechargeable.

SHORT FORM SPECIFICATIONS

Cres Cor Insulated Hot Cabinet Model HC-UA-11 outer of .063 aluminum, stainless steel internal frame. (11) sets of locking transport angles for multiple pan sizes, adjustable spacing every 1-1/2". Inner body stainless steel. Fiberglass insulation in sides; doors, back, top, and sidewalls 1-1/2". Interior coved corners. Hose out cleaning capability. 1500 Watt, 120 Volt power unit. One piece base, stainless steel. 8" all-terrain wheels, front swivel with brake, rear wheels are fixed. Load capacity 310 lbs. each. 2 year parts warranty. 2-Year Parts / 1-Year Labor warranty. Provide the following accessories: _____ CSA-US, CSA-C listed, CSA Sanitation, CSA Gas Canada, CSA design certified US and Energy Star Qualified.

In line with its policy to continually improve its products, CRES COR reserves the right to change materials and specifications without notice.