

12 Cup Automatic Coffee Brewer

Features

12 Cup Automatic Coffee Brewer

- Brews 3.8 to 7.5 gallons (14.4 to 28.4 litres) of perfect coffee per hour.
- Model is space-saving 8.5" (21.6 cm) wide.
- All stainless steel construction.
- Hot water faucet and pourover feature on all models.
- SplashGard® funnel deflects hot liquids away from the hand.
- International electrical configurations available.



Model CWTF15-3*
(decanters sold separately)

Dimensions: 18.9" H x 8.5" W x 17.8" D
(48cm H x 21.6cm W x 45.2cm D)



Model CWTF15-2
(decanters sold separately)

Dimensions: 18.9" H x 8.5" W x 17.8" D
(48cm H x 21.6cm W x 45.2cm D)



Model CWTF15-1
(decanters sold separately)

Dimensions: 16.8" H x 8.5" W x 17.8" D
(42.7cm H x 21.6cm W x 45.2cm D)

For current specification sheets and other information, go to www.bunn.com.

* International models may vary in appearance.

Related Products

Easy Clear® EQ-17-TL

Product No. : 30200.1000

Dimensions:

12⁷/₁₆" H x 2¹/₂" W x 3" D
31.6 cm H x 6.35 cm W x 7.62 cm D



Paper Filter Pack

Product No. : 20115.0000

Packed per case: 1,000

Dimensions: 4¹/₄" Base x 2³/₄" Sidewall
10.8 cm Base x 6.98 cm Sidewall



1GPR SS Portable Server on an RWS1 Warmer

1GPR Product No. : 12487.0001*

RWS1 Product No. : 12203.0010

*Also available with side handles or black decor.



Easy Clear® ED-17-TL

Product No. : 30201.1001

Dimensions: 8¹/₄" H x 2⁵/₁₆" Dia.
20.95 cm H x 5.87 cm Dia.

Easy Pour® black decanter

Product No. : 06100.0101

Quantity: 1 (also packaged in quantities of 2, 3, 6, 12, & 24)



Easy Pour® orange decanter (for decaf)

Product No. : 06101.0101

Quantity: 1 (also packaged in quantities of 2, 3, 6, 12, & 24)



Model

Agency Listing

CWTF15



CWTF20



CWTF35



Dimensions & Specifications

Model	Product #	Volts	Amps	Tank Heater Watts	Total Watts	Brewing Capacity	Cu. Ft.	Shipping Weight	Cord Attached
CWTF15-1	12950.0293	120	12.3	1320	1470	3.8 gal./hr.	3.9	27 lbs.	Yes
CWTF15-2	12950.0211	120	13	1320	1570	3.8 gal./hr.	3.9	33 lbs.	Yes
CWTF15-3	12950.0213	120	14	1320	1670	3.8 gal./hr.	3.9	33 lbs.	Yes
CWTF15-3	12950.0217	120	13.9	1320	1670	3.8 gal./hr.	3.9	34 lbs.	Yes
CWTF20-3	12950.0283	120	17.9	1800	2150	5.1 gal./hr.	3.9	34 lbs.	No
CWTF35-3	12950.0253	120/208-240	17.1*	3500	3850	7.5 gal./hr.	3.9	33 lbs.	No
CWTF35-3	12950.0261	120/208-240	17.1*	3500	3850	7.5 gal./hr.	3.9	34 lbs.	No
CWT15	12950.0356	120	13.9	1320	1670	3.8 gal./hr.	3.9	30 lbs.	Yes
CWT20	12950.0291	120	17.9	1800	2150	5.1 gal./hr.	3.9	30 lbs.	No
CWT35	12950.0292	120/240	17.1	3500	3850	7.5 gal./hr.	3.9	30 lbs.	No

*17.1 Amps @ 120/240 Volts

Brewing capacity: based upon incoming water temp of 60°F (140°F rise) per 1/2 gallon brew time of 4 minutes.

Models listed as 120/208V or 120/240V must be connected to 208V or 240V electrical service respectively. Please refer to the installation manual.

Electrical: Model 15 requires 2-wires plus ground service rated 120V, single phase, 60 Hz.

Model 20 requires 2-wires plus ground service rated 120V, single phase, 60 Hz.

Model 35 requires 3-wires plus ground service rated 120/208 or 120/240V, single phase, 60 Hz.

Plumbing: 20-90 psi (138-621 kPa). Machine supplied with 1/4" male flare fitting.

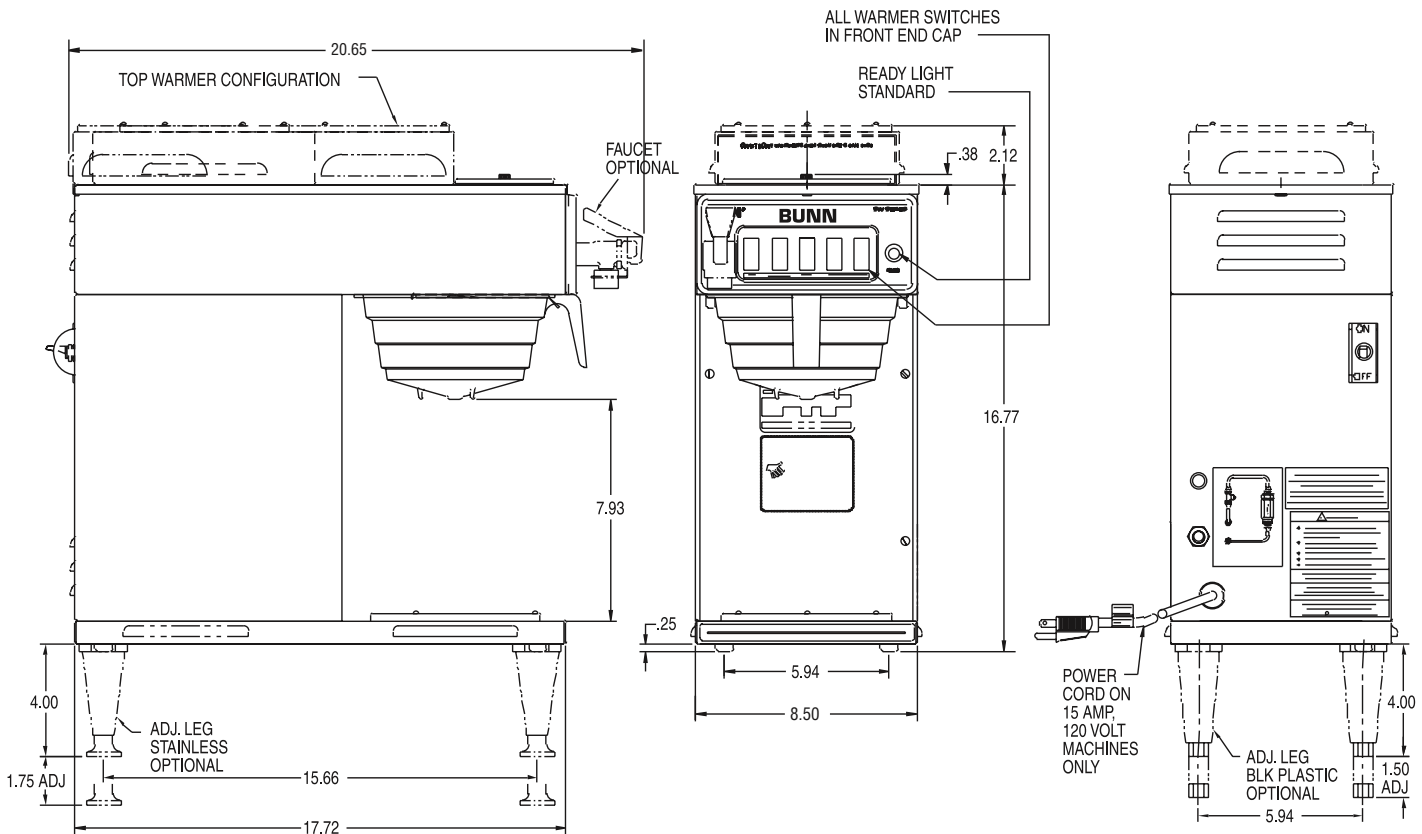

BUNN Corporation - 1400 Stevenson Drive Springfield, Illinois 62703 • 800-637-8606 • 217-529-6601 • Fax 217-529-6644 • www.bunn.com

BUNN® practices continuous product research and improvement. We reserve the right to change specifications and product design without notice. Such revisions do not entitle the buyer to corresponding changes, improvements, additions or replacements for previously purchased equipment.

All dimensions shown in inches. Bunn Corporation owns all copyrights relating to materials in this publication. Please contact Bunn Corporation to request permission to reproduce any portion of this publication.

Central Restaurant Products