

# BUNN®

## 5 Gallon Portion Control Dual Voltage Hot Water Machine

ITEM#

PROJECT

DATE



### Model H5E-DV PC

Dimensions: 28.4"H x 7"W x 15.5"D  
(72.1cm H x 17.8cm W x 39.4cm D)

### Features

#### 5 Gallon Portion Control Hot Water Machine

- Locate hot water at preparation site to increase speed, safety and efficiency of kitchen staff.
- Prepare large amounts of mashed potatoes, gravy, cheese sauce, gelatin, oatmeal, and many more foods.
- Dispenses hot water in three portion sizes.
- Precise electronic temperature control (65°F-205°F) (18.3°C-96.1°C) ensures consistent water temperature.
- Three programmable volume settings and one push and hold continuous dispense button.
- Front of machine volume programming.

For current specification sheets and other information, go to [www.bunn.com](http://www.bunn.com).

### Related Products

Easy Clear® EQHP-10L  
Product No. : 39000.0001

Easy Clear® EQHP-25L  
Product No. : 39000.0002

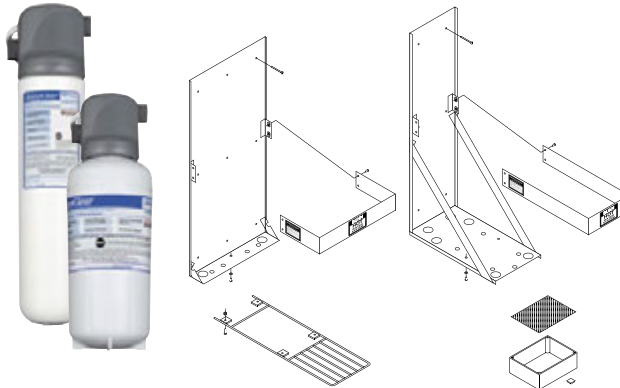

#### 1. Wall Mount Bracket (side)

Product No. : 12542.0000  
Dimensions: 30" H x 13 1/2" W x 4 1/2" D  
76.2 cm H x 34.29 cm W x 11.43 cm D

#### 2. Wall Mount Bracket (front)

Product No. : 13125.0001  
Dimensions: 30 1/2" H x 8 1/2" W x 15 1/4" D  
77.47 cm H x 21.59 cm W x 38.74 cm D

#### 3. Container Holding Shelf

Product No. : 12599.0000  
Dimensions: 6 3/4" W x 21" D  
17.15 cm W x 53.34 cm D

#### 4. Drip Tray

Product No. : 02497.0000

#### Model

H5E-DV PC

#### Agency Listing



## Dimensions & Specifications

Model	Product #	Volts	Amps	Tank Heater Watts	Total Watts	°F Settings	Gal./Hr.† cold water input 35°	Gal./Hr.† hot water input 140°	Cubic Ft.	Shipping Weight	Cord Attached
H5E-DV PC	39100.0000	120	15.3	1800	1850	200°F*	3.7	8.1	4.0 ft <sup>3</sup>	35 lbs.	No
		240	17.4	4000	4180		7.3	14.7			
H5E-DV PC	39100.0001	120	15.3	1800	1850	90°F*	8.1	n/a	4.0 ft <sup>3</sup>	35 lbs.	No
		240	17.4	4000	4180		14.7	n/a			

Electrical: All models require 2-wires plus ground service, single-phase. Supplied strain relief on rear side of machine.

Plumbing: 20-90 psi (138-621 kPa). Machine supplied with 1/4" OD male flare fitting.

\* Adjustable 65°F to 205°F.

† Based upon a maximum single dispense of 2 gallons per portion.

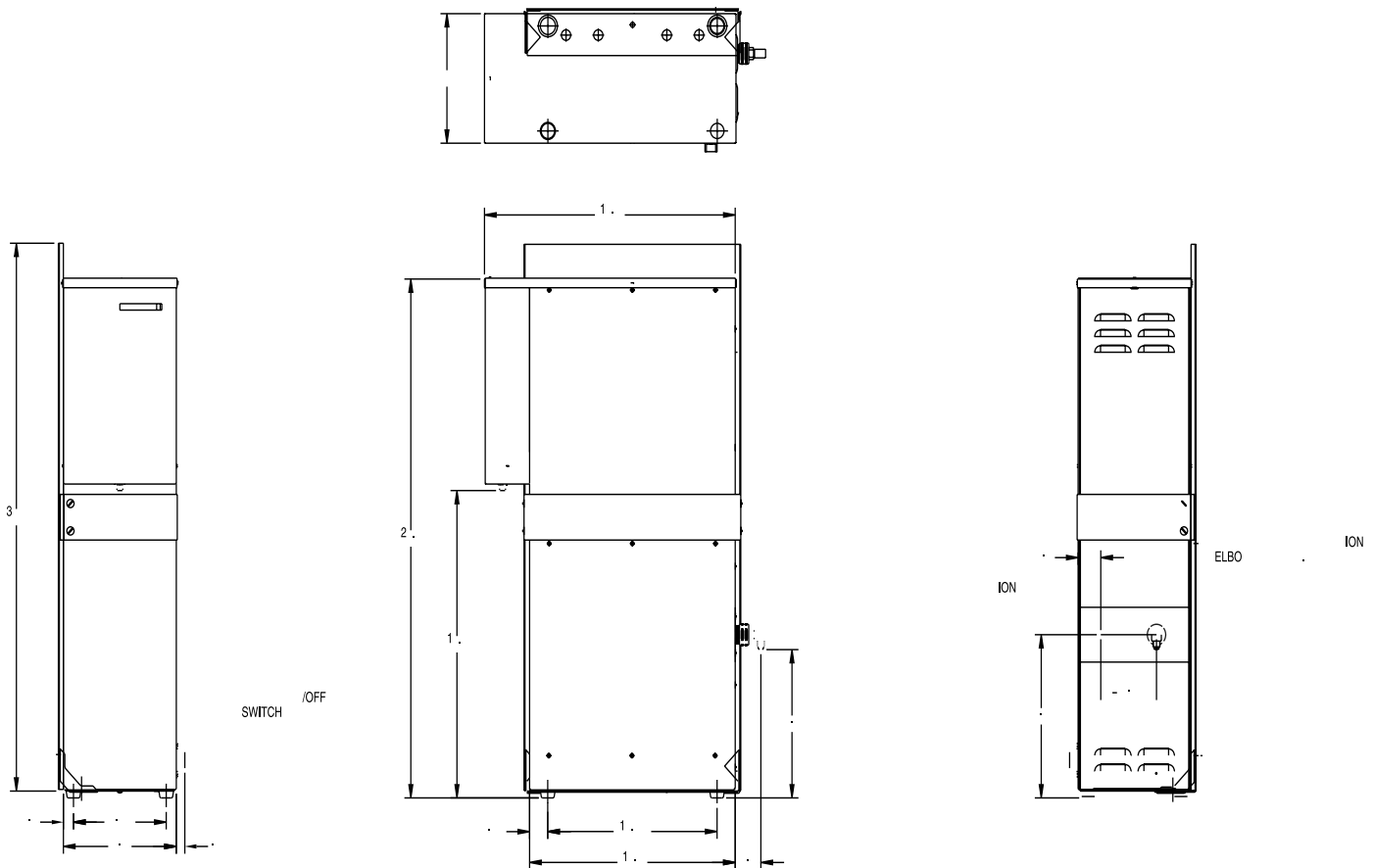

BUNN Corporation - 1400 Stevenson Drive Springfield, Illinois 62703 • 800-637-8606 • 217-529-6601 • Fax 217-529-6644 • www.bunn.com

BUNN® practices continuous product research and improvement. We reserve the right to change specifications and product design without notice. Such revisions do not entitle the buyer to corresponding changes, improvements, additions or replacements for previously purchased equipment.

All dimensions shown in inches. Bunn Corporation owns all copyrights relating to materials in this publication. Please contact Bunn Corporation to request permission to reproduce any portion of this publication.

Central Restaurant Products