

CW15-TC w/Plastic Funnel

Height: 24.1" (61.2cm) Width: 9.0" (22.9cm) Depth: 21.4" (54.4cm)



- Models are space saving 9" wide (22.9cm)
- All stainless steel construction
- Pourover brewer requires no plumbing – completely portable
- SplashGard® funnel deflects hot liquids away from the hand
- Accommodates thermal carafe up to 8.5" (21.6 cm) tall
- Use in quick turn environments where high quality coffee is continuously refreshed
- PROP 65 Warning Decal included in packaging with equipment
- Servers not included unless otherwise noted

Server(s) sold separately

Agency:



Specifications

Product #: 23001.0040

Water Access: Not Plumbed

Finish: Stainless

Funnel: Black Plastic

Additional Features

Electrical & Capacity

Volts*	Amps	Watts	Cord Attached	Plug Type	8oz cups/hr 236ml cups/hr	Input H ₂ O Temp.	Phase	# Wires plus Ground	Hertz
120	11.4	1370	Yes	NEMA 5-15P	62	60°F (15.5°C)	1	2	60

*When a BUNN is machine rated 120/208-240V, 120/208V or 120/240V, the higher voltage is the supply voltage needed to power the machine. The 120V is there to supply power to some components rated 120V in the machine, but it is not the supply voltage and would not power the machine if the machine is marked with the before mentioned ratings.

Plumbing Requirements

PSI	kPa	Fitting Supplied	Water Flow Required (GPM)
-	-	-	-

CAD Drawings

2D	Revit	KLC
●		

WARNING: This product can expose you to chemicals including Bisphenol A (BPA), which is known to the State of California to cause birth defects or other reproductive harm. For more information go to www.P65Warnings.ca.gov



BUNN® reserves the right to change specifications and product design without notice. Such revisions do not entitle the buyer to corresponding changes, improvements, additions or replacements for previously purchased equipment. For most current specifications and other info visit bunn.com.

Last Updated:
07/13/2022

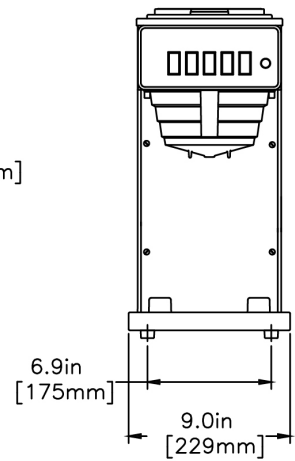
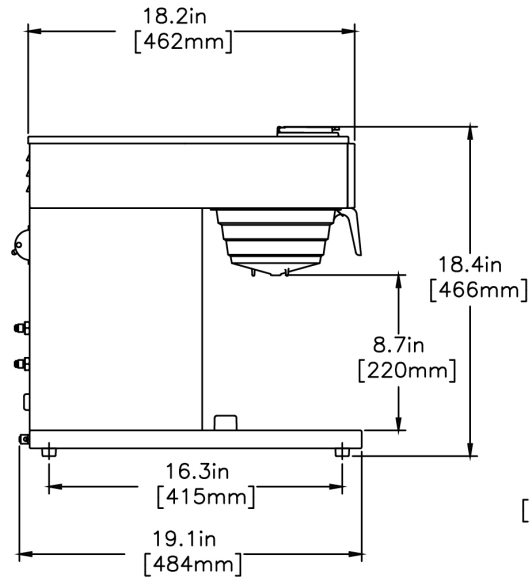
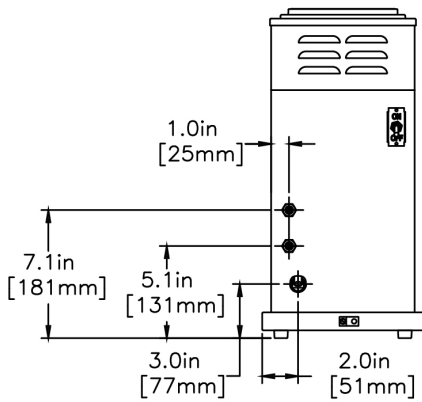
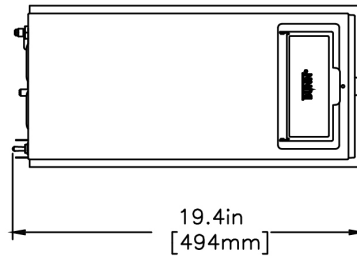

	Unit			Shipping				
	Height	Width	Depth	Height	Width	Depth	Weight	Volume
English	24.1 in.	9.0 in.	21.4 in.	24.8 in.	11.9 in.	25.9 in.	29.200 lbs	4.401 ft ³
Metric	61.2 cm	22.9 cm	54.4 cm	62.9 cm	30.2 cm	65.7 cm	13.245 kgs	0.125 m ³



BUNN® reserves the right to change specifications and product design without notice. Such revisions do not entitle the buyer to corresponding changes, improvements, additions or replacements for previously purchased equipment. For most current specifications and other info visit bunn.com.

Last Updated:
07/13/2022

Related Products & Accessories: CW15-TC w/Plastic Funnel(23001.0040)



FUNNEL W/DECAL,PPK
NAR BLK(SM)

Product #: 02774.0011



FUNNEL W/DECAL,PPK
NAR BLK(LG)

Product #: 04274.0012



FILTERS,REGULAR1M
500/2 50/CL

Product #: 20115.0000



FUNNEL ASSY, SST-BLK
HDL(7.12)

Product #: 20216.0000



FUNNEL ASSY, SST-PP
BLK HNDL

Product #: 29151.0000



FUNNEL ASSY,SST-PP
ORANGE HDL

Product #: 29151.0001



WATER FILTER
SYSTEM,EQ-17-TL

Product #: 30200.1000



SYSTEM, WEQ-10(1.5)5L

Product #: 56000.0024



CARTRIDGE, WEQ-10
(1.5)5L

Product #: 56000.0121



CARTRIDGE, WEQ-10.3
(1.67)5L

Product #: 56000.0137



BUNN® reserves the right to change specifications and product design without notice. Such revisions do not entitle the buyer to corresponding changes, improvements, additions or replacements for previously purchased equipment. For most current specifications and other info visit bunn.com.

Last Updated:
07/13/2022

Serving & Holding Options: CW15-TC w/Plastic Funnel(23001.0040)



THERMAL CARAFE, BLK
1.9L 12PK

Product #:36029.0000



THERMAL CARAFE, BLK
1.83 L 1PK

Product #:36029.0001



THERMAL CARAFE,ORN
1.9L 12PK

Product #:36252.0000



THERMAL CARAFE,ORN
1.9L 1PK

Product #:36252.0001



CARAFE,SST 1.9L SHRT
BLK 1

Product #:40163.0000



BUNN® reserves the right to change specifications and product design without notice. Such revisions do not entitle the buyer to corresponding changes, improvements, additions or replacements for previously purchased equipment. For most current specifications and other info visit bunn.com.

Last Updated:
07/13/2022