

**REFRIGERATOR MANUFACTURER**  
**Turbo air**  
 more durable, efficient, beautiful

4184 E. Conant St.  
 Long Beach, CA 90808  
 Tel. 310-900-1000  
 Fax. 310-900-1077  
[www.turboairinc.com](http://www.turboairinc.com)

Project :	
Model # :	
Item # :	Qty :
Available W/H :	
Approval :	

## Diamond Show Case

*Display Cases  
 Refrigerated Show Cases*

**Model : CRT-77-1R**



### ≡ FEATURES / BENEFITS ≡

- **EFFICIENT REFRIGERATION SYSTEM**  
 Turbo Air's refrigerators are designed with oversized and balanced R-134A (CFC Free) refrigeration. These include efficient evaporators and condensers for faster cooling and greater efficiency.
- **BEAUTIFUL 4 SIDED GLASS CABINET ALLOWS VISIBILITY FROM ALL SIDES TO OPTIMIZE DISPLAY EFFECT**
- **SAFETY SHIELDED 4 LED LIGHTING SYSTEM ON EVERY CORNER OF THE CABINET ENSURES A LONGER LIFE AND BRIGHTER LIGHTING THAN FLUORESCENT LIGHT BULBS, PROVIDING ATTRACTIVE, ENHANCED AND SHADOW-FREE ILLUMINATION**
- **COMPACT SIZE AND COUNTERTOP DESIGN OCCUPIES MINIMUM SPACE BUT MAXIMIZE IMPULSE SALES**
- **ITS GREAT SPACE EFFICIENCY IS IDEAL FOR NARROW SPACE RESTAURANTS AND CONVENIENCE STORES**
- **ELEGANT CONTEMPORARY EURO DESIGN WILL ENHANCE THE INTERIOR AND SPACE DECORATION OF ANY STORE**
- **STURDY, CLEAN STAINLESS SHELVING**  
 Shelves are the most important part of cleanliness as they come in direct contact with food. After a while, PVC coated wire shelves may peel, rust and lead to unsanitary conditions. Only the Turbo Air Diamond Show Case uniquely provides stainless shelving.



Model	Swing Door	CU./FT.	# of Shelves	HP	AMPS	Crated Weight (lbs.)	L x D x H (inches)
<b>CRT-77-1R</b>	<b>1</b>	<b>3.0</b>	<b>3</b>	<b>2/9</b>	<b>2.6</b>	<b>89</b>	<b>16 3/4 x 16 x 38 1/2</b>

## Model : CRT-77-1R

ELECTRICAL DATA	
Voltage	115/60/1
Plug Type	ⓘ NEMA-5-15P
Full Load Amperes	2.6
Compressor HP	2/9
Refrigerant	R-134A
Cord Length (ft.)	6.5
DIMENSIONAL DATA	
Net Capacity cu. ft.	3
Ext. Length Overall in.	16 <sup>3</sup> / <sub>4</sub> (425mm)
Ext. Depth Overall in.	16 (406mm)
Ext. Height Overall in.	38 <sup>1</sup> / <sub>2</sub> (978mm)
Int. Length Overall in.	14 <sup>3</sup> / <sub>8</sub> (366mm)
Int. Depth Overall in.	12 <sup>3</sup> / <sub>4</sub> (324mm)
Int. Height Overall in.	25 (635mm)
Gross Weight lbs.	89
Net Weight lbs.	81.5
# of Shelves	3
Self Size	14 <sup>3</sup> / <sub>8</sub> x 12 <sup>3</sup> / <sub>4</sub>

Design and specifications subject to change without notice.  
Actual shipping weight may differ due to extra packing materials for product protection.

- **WARRANTY : 1 Year Parts and Labor Warranty**  
Additional 4 Year Warranty on Compressor

- **SELF-CONTAINED SYSTEM**

## PLAN VIEW

(unit : inch)

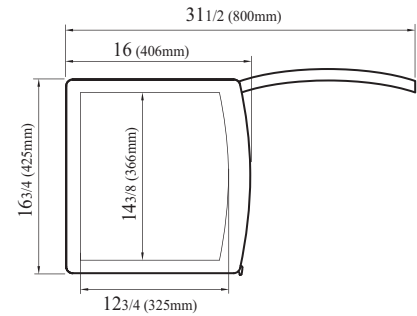

## PLAN VIEW

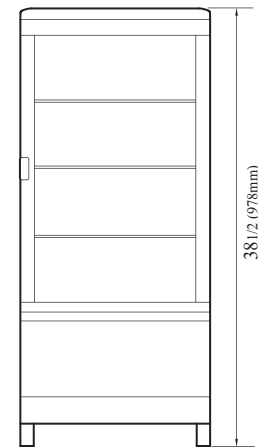

## FRONT VIEW

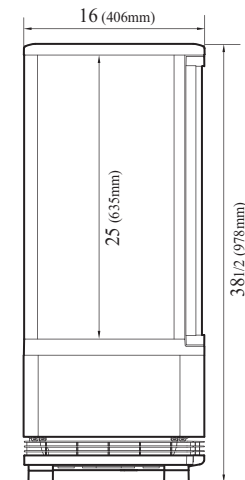

## SIDE VIEW

Ver.201408



- Turbo Air : 800-627-0032
- GK : 800-500-3519
- Warranty : 800-381-7770
- AC : 888-900-1002