

**REFRIGERATOR MANUFACTURER**  
**Turbo air**  
 more durable, efficient, beautiful

4184 E. Conant St.  
 Long Beach, CA 90808  
 Tel. 310-900-1000  
 Fax. 310-900-1077  
[www.turboairinc.com](http://www.turboairinc.com)

|                 |       |
|-----------------|-------|
| Project :       |       |
| Model # :       |       |
| Item # :        | Qty : |
| Available W/H : |       |
| Approval :      |       |

## Worktop Freezer

Worktops  
 Super Deluxe Series

**3 YEAR PARTS & LABOR WARRANTY**

**Model : TWF-28SD**



### FEATURES & BENEFITS

- Stainless steel cabinet construction**  
 The Turbo Air Super Deluxe model boasts a stainless steel interior and exterior (galvanized steel back & bottom). It guarantees the utmost in cleanliness and long product life. The Super Deluxe can add a touch of style to the most refined setting.
- Sturdy, clean stainless steel shelving**  
 Shelves are the most important part of cleanliness as they come in direct contact with food. After a while, PVC coated wire shelves may peel, rust and lead to unsanitary conditions. Only the Turbo Air Super Deluxe series uniquely provides stainless steel shelving.
- LED interior lighting system**  
 Brighter and longer lasting LED lights provide attractive, enhanced illumination compared to fluorescents. It saves energy by producing less heat, while maximizing the visibility.
- Efficient refrigeration system**  
 Turbo Air's solid door freezers are designed with oversized and balanced (CFC Free R-134A, R-404A) refrigeration systems. These include efficient evaporators and condensers for faster freezing and greater efficiency.
- High-density polyurethane insulation**  
 The entire cabinet structure and solid doors are foamed-in-place using high density, CFC free polyurethane insulation.
- Ergonomically designed doors**  
 Customers' fatigue fades away with easy grip handles and doors that open effortlessly. These features along with self-closing doors make this the ultimate choice in customer convenience. ABS sheet door liners resist water condensation with thermal efficiency.
- Magnetic door gaskets**  
 Magnetic door gaskets are of one piece construction, removable without tools for ease of cleaning and replacement.
- Freezer holds 0°F ~ -10°F for the best in frozen food preservation**

ENERGY STAR®  
 Qualified



| Model    | Swing Door | CU./FT. | #of Shelves | HP  | AMPS | Crated Weight (lbs.) | L x D* x H† (inches) |
|----------|------------|---------|-------------|-----|------|----------------------|----------------------|
| TWF-28SD | 1          | 7       | 1           | 1/3 | 5.3  | 175                  | 27 1/2 x 30 x 33 1/2 |

## Model : TWF-28SD

| ELECTRICAL DATA          |                |
|--------------------------|----------------|
| Voltage                  | 115/60/1       |
| Plug Type                | Ⓜ NEMA 5-15P   |
| Full Load Amperes        | 5.3            |
| Compressor HP            | 1/3            |
| Cord Length ft.          | 9              |
| Refrigerant              | R-404A         |
| DIMENSIONAL DATA         |                |
| Net Capacity cu. ft.     | 7              |
| Ext. Length Overall in.  | 27 1/2 (699mm) |
| Ext. Depth Overall in.*  | 30 (762mm)     |
| Ext. Height Overall in.† | 33 1/2 (851mm) |
| # of Doors               | 1              |
| # of Shelves             | 1              |
| Net Weight lbs.          | 157            |
| Gross Weight lbs.        | 175            |

Design and specifications subject to change without notice.  
Actual shipping weight may differ due to extra packing materials for product protection.  
\* Depth does not include 1" for rear spacers.  
† Height does not include 5-7/8" for caster height.

■ **WARRANTY : 3 Year Parts and Labor Warranty**  
Additional 2 Year Warranty on Compressor

- Self-contained system
- Standard 4" swivel casters with locks on the front set
- 2.5" dia. casters available - 1/2" diameter & 13 TPI (optional)
- Legs available for all models (optional)
- Door locks available (optional)
- External digital thermometer available (optional)

■ **OPTIONAL ACCESSORIES :**

- 2.5" Diameter casters
- 5" Diameter casters
- 6" ABS plastic legs
- Additional stainless steel shelves
- Additional PE coated wire shelves

## PLAN VIEW

(unit : inch)

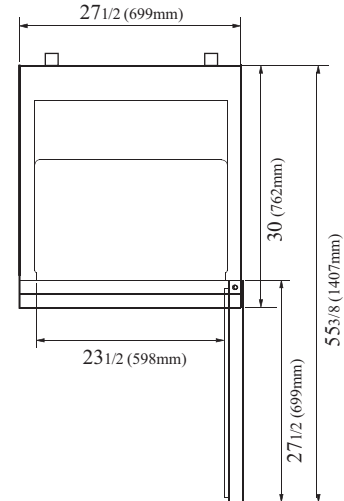

PLAN VIEW

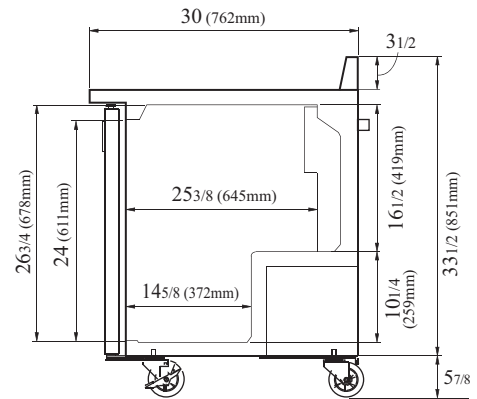

SIDE VIEW

Ver.201501



- Turbo Air : 800-627-0032
- GK : 800-500-3519
- Warranty : 800-381-7770
- AC : 888-900-1002