

REFRIGERATOR MANUFACTURER
Turbo air
 more durable, efficient, beautiful

4184 E. Conant St.
 Long Beach, CA 90808
 Tel. 310-900-1000
 Fax. 310-900-1077
www.turboairinc.com

Project :	
Model # :	
Item # :	Qty :
Available W/H :	
Approval :	

Sandwich / Salad Unit - Drawers

Food Prep Tables
 Super Deluxe Series

3 YEAR PARTS & LABOR WARRANTY

Model : TST-28SD-D2



- Each drawer accommodates up to 6" deep sixth (1/6) size pans (drawer pans not included)

≡ FEATURES & BENEFITS ≡

■ **Stainless steel cabinet construction**

The Turbo Air Super Deluxe model boasts a stainless steel interior and exterior (galvanized steel back & bottom). It guarantees the utmost in cleanliness and long product life. The Super Deluxe can add a touch of style to the most refined setting.

■ **Sturdy, clean stainless steel shelving**

Shelves are the most important part of cleanliness as they come in direct contact with food. After a while, PVC coated wire shelves may peel, rust and lead to unsanitary conditions. Only the Turbo Air Super Deluxe series uniquely provides stainless steel shelving.

■ **Durable stainless steel drawers**

Drawers are easy to clean and assemble.

■ **Convenient cutting board side rail**

Our cutting board is 9-1/2" deep and 1/2" thick to provide ample working space, and is made of easy to use and sanitize LDPE (Low Density Polyethylene). The new side rail cutting board bracket makes it easy to secure and remove the cutting board and it accepts different sizes too (max. 1/2" thickness)

■ **Insulated pan cover**

■ **Efficient refrigeration system**

Turbo Air's solid door refrigerators are designed with oversized and balanced (CFC Free R-134A) refrigeration systems. These include efficient evaporators and condensers for faster cooling and greater efficiency.

■ **High-density polyurethane insulation**

The entire cabinet structure and solid doors are foamed-in-place high density, CFC free polyurethane insulation.

■ **Magnetic door gaskets**

Magnetic door and drawer gaskets are of one piece construction, removable without tools for ease of cleaning and replacement.

■ **Ergonomically designed doors & drawers**

Customers' fatigue fades away with easy door grip and drawers that open effortlessly. These features along with self-closing doors make this the ultimate choice in customer convenience. ABS sheet door liners resist water condensation with thermal efficiency.

■ **Refrigerator holds 33°F ~ 39°F for the best in food preservation**



Model	Swing Door	Drawers	CU./FT.	#of Shelves	#of Pans	HP	AMPS	Crated Weight (lbs.)	L x D* x H† (inches)
TST-28SD-D2	-	2	7	-	8	1/4	6.6	205	27 1/2 x 30 x 37

Model : TST-28SD-D2

ELECTRICAL DATA	
Voltage	115/60/1
Plug Type	Ⓜ NEMA 5-15P
Full Load Amperes	6.6
Compressor HP	1/4
Cord Length ft.	9
Refrigerant	R-134A
DIMENSIONAL DATA	
Ext. Length Overall in.	27 1/2 (698mm)
Ext. Depth Overall in.*	30 (762mm)
Ext. Height Overall in.†	37 (940mm)
# of Doors	-
# of Drawers	2
# of Shelves	-
# of Pans	8
Net Capacity cu. ft.	7
Gross Weight lbs.	205
Net Weight lbs.	187

Design and specifications subject to change without notice.

Actual shipping weight may differ due to extra packing materials for product protection.

* Depth does not include 1" for rear spacers.

† Height does not include 5-7/8" for caster height.

■ **WARRANTY : 3 Year Parts and Labor Warranty
Additional 2 Year Warranty on Compressor**

- **Self-contained system**
- **Standard 4" swivel casters with locks on the front set**
- **Standard 1/6 size, 4" deep condiment pans included (top of cabinet)**
- **9 1/2" deep, 1/2" thick cutting board included**
- **Door locks available (optional)**
- **External digital thermometer available (optional)**
- **2.5" dia. casters available (optional) - 1/2" diameter & 13 TPI**
- **Legs available for all models (optional)**

■ **OPTIONAL ACCESSORIES :**

- 2.5" Diameter casters
- 5" Diameter casters
- 6" ABS plastic legs

PLAN VIEW

(unit : inch)

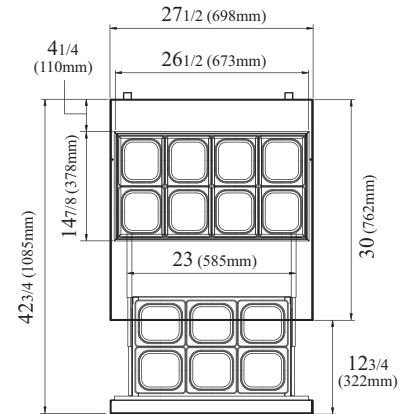

PLAN VIEW

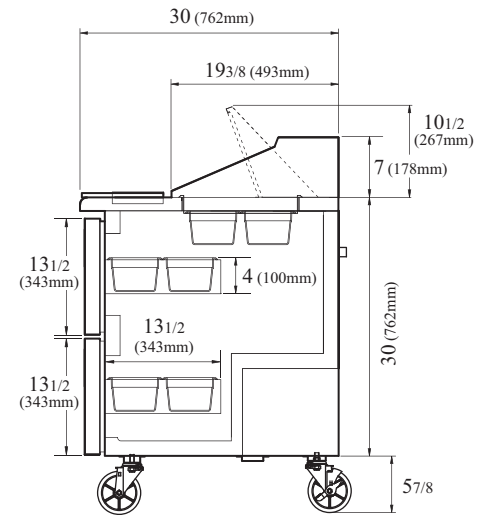

SIDE VIEW

Ver.201501



- Turbo Air : 800-627-0032
- GK : 800-500-3519
- Warranty : 800-381-7770
- AC : 888-900-1002