

REFRIGERATOR MANUFACTURER
Turbo air
 more durable, efficient, beautiful

4184 E. Conant St.
 Long Beach, CA 90808
 Tel. 310-900-1000
 Fax. 310-900-1077
www.turboairinc.com

Project :	
Model # :	
Item # :	Qty :
Available W/H :	
Approval :	

Ice Cream Dipping Cabinets

Model : TIDC-70W(G)



TIDC-70W

TIDC-70G



**TIDC-70W
Back View**

≡ FEATURES & BENEFITS ≡

■ **Locked-in temperature equal from top to bottom**

New technology of the Cold Wall System eliminates temperature fluctuations throughout the top and bottom areas of the interior cabinet. No more melting ice cream above while freezing below. Scooping has never been easier.

■ **Attractive contemporary design with curved glass front and top**

Sleek new curved front and top glass is attractive and draws attention at once. Deep lowered glass front optimizes product visibility and impulse buying. This merchandiser is perfect for ice cream viewing and dipping.

■ **LED lighting for interior canopy**

Brighter and longer lasting LED light bulbs produce less heat, saving energy while maximizing its display effect. Independent on/off light switch equipped.

■ **Extra storage space**

Extra storage space to accommodate additional ice cream tubs underneath the basket. Doors located to the rear allows easy access to the storage area eliminating inconvenient bracket usage in picking up ice cream tubs.

■ **Easy grip rack handles**

PE coated wire container racks have easy grip handles for convenient product removal.

■ **Efficient refrigeration system**

Turbo Air's dipping cabinets are designed with oversized and balanced (CFC Free R-134A and R-404A) refrigeration systems. These include efficient evaporators and condensers for faster freezing and greater efficiency.

■ **Standard plastic can holder for each container rack**

Each container rack comes standard with an ABS plastic can holder in standard. Attached on top of the ice cream containers, it holds the container firmly in place and provides attractive display appearance.

■ **Manual defrost system**

■ **PE coated removable magnetic frost shields**

Provides fast and easy removal of accumulated frost on inside walls.

■ **Standard plastic night covers for case opening**

■ **Maintains -10°F ~ 8°F for the best in frozen Ice cream preservation**



Model	# of Lids	# of Racks	# of Night Covers	Capacity 3 Gallon(12Liter) cans		HP	AMPS	Crated Weight (lbs.)	L x D x H (inches)
				Total	Display - Storage -				
TIDC-70W(G)	2	12	3	20	12 8	1	7.0	518	68 x 26 1/8 x 49 5/8

Ice Cream Dipping Cabinets

Model : TIDC-70W / TIDC-70G

ELECTRICAL DATA	
Voltage	115/60/1
Plug Type	Ⓜ NEMA 5-15P
Full Load Amperes	7.0
Compressor HP	1
Refrigerant	R-404A
DIMENSIONAL DATA	
Capacity ^(3gal. cans) Display / Storage	12 / 8
Ext. Length Overall in.	68 (1726mm)
Ext. Depth Overall in.	26 1/8 (663mm)
Ext. Height Overall in.	49 5/8 (1259mm)
# of Lids	1
# of Night Covers	2
# of Racks	8
Net Weight lbs.	419
Gross Weight lbs.	518

Design and specifications subject to change without notice.
Actual shipping weight may differ due to extra packing materials for product protection.

- **WARRANTY : 2 Year Parts and Labor Warranty**
Additional 3 Year Warranty on Compressor
- *These models are designed to operate in air conditioned environments where temperature and humidity are below 75°F and 55% relative humidity*
- *Place units away from direct sunlight, rapid air movement and extreme temperature changes*
- *White (W) and lime color (G) exterior available*
- *Optional 2.5" casters available - 1/2" diameter & 13 TPI (threads per inch)*

PLAN VIEW

(unit : inch)

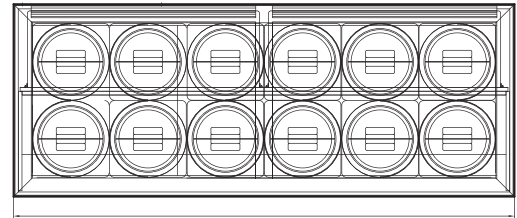

68 (1726mm)

PLAN VIEW

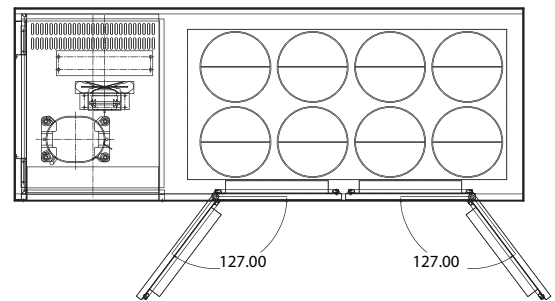

PLAN VIEW - Bottom

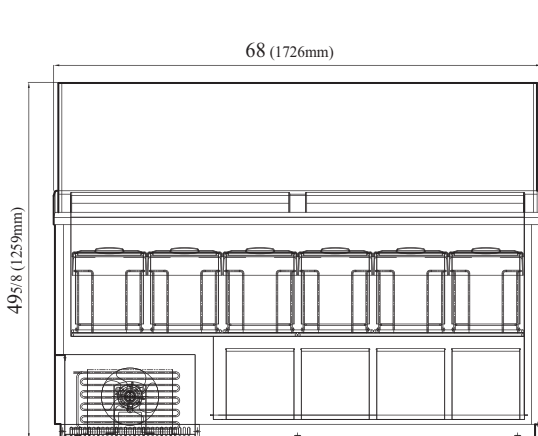

FRONT VIEW

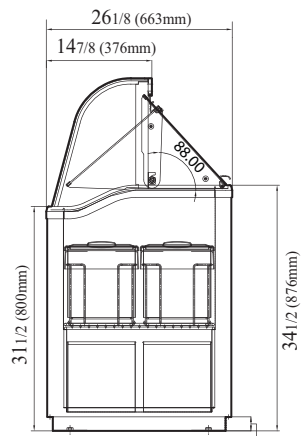

SIDE VIEW

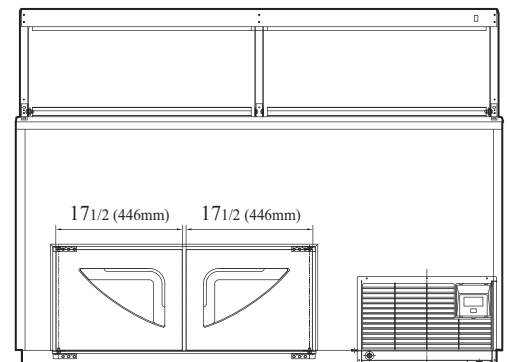

BACK VIEW

Ver.201501



- Turbo Air : 800-627-0032
- GK : 800-500-3519
- Warranty : 800-381-7770
- AC : 888-900-1002

REFRIGERATOR MANUFACTURER
Turbo air

GERMAN KNIFE

RADIANCE

GREEN WORLD

AIR CONDITIONER MANUFACTURER
Turbo air