

REFRIGERATOR MANUFACTURER
Turbo air
 more durable, efficient, beautiful

4184 E. Conant St.
 Long Beach, CA 90808
 Tel. 310-900-1000
 Fax. 310-900-1077
www.turboairinc.com

Project :	
Model # :	
Item # :	Qty :
Available W/H :	
Approval :	

Ice Merchandiser

Ice Merchandisers
 Glass Door Merchandisers

Model : TGIM-49

FEATURES & BENEFITS

- **Digital temperature control system**
 Provides precise and constant temperature. This level of precision allows food products to remain fresh over an extended period of time.
- **High-tech monitor**
 The unit will beep if the door has been opened for more than 30 seconds. The monitor digitally displays the present temperature and current status of the freezer. You can easily change the temperature by adjusting the thermostat.
- **Efficient refrigeration system**
 Turbo Air's freezers are designed with oversized and balanced (CFC Free R-404A) refrigeration systems. These include efficient evaporators and condensers for faster freezing and greater efficiency.
- **Ice does not melt even in hot climates**
 Turbo Air ice merchandisers are based on a freezer system which is adjusted to the ideal temperature range for bagged ice storage, whereas our competitors use refrigerator based systems. It maintains an avg. temperature of 12°F or below and eliminates ice melting problems during hot weather conditions.
- **LED lighting interior display system**
 Brighter and longer lasting LED lights provide attractive, enhanced illumination compared to fluorescents. It saves energy by producing less heat, while maximizing the visibility in the display area.
- **LED advertising panel**
 LED lighting offers 10 times longer lasting life than fluorescents and conserves energy as well.
- **Triple pane heated glass doors**
 Equipped with unique triple-pane heated glass doors which enhance energy efficiency by preventing heat transfers and minimizing condensation. Lightweight door construction reduces door maintenance, bushing wear, and facilitates smooth door opening.
- **Automatic evaporator fan motor delays**
 When the door is opened the evaporator fan will stop, preventing the circulation of hot and moist air from escaping into the refrigerator. This increases energy efficiency and lengthens the life of the compressor.
- **High-density polyurethane insulation**
 The entire cabinet structure is foamed-in-place using high density, CFC free polyurethane insulation.
- **Magnetic door gaskets**
 Magnetic door gaskets are of one piece construction, removable without tools for ease of cleaning and replacement.
- **Bottom mount compressor units**
 Turbo Air's bottom mount compressor allows easier access for service and extra storage space above. In addition, the lower area provides a cooler and less greasy operating environment which results in reduced compressor running time.



Freezer holds 10°F ~ 15°F for the best in bagged ice storage



Model	Swing Door	CU./FT.	HP	AMPS	Crated Weight (lbs.)	L x D* x H (inches)
TGIM-49	2	46.2	2/3	11.8	665	54 3/8 x 29 3/4 x 77

Model : TGIM-49

ELECTRICAL DATA	
Voltage	115/60/1
Plug Type	Ⓜ NEMA 5-15P
Full Load Amperes	11.8
Compressor HP	2/3
Cord Length ft.	7
Refrigerant	R-404A
DIMENSIONAL DATA	
# of Doors	2
Net Capacity cu. ft.	46.2
Ext. Length Overall in.	54 ³ / ₈ (1382mm)
Ext. Depth Overall in.*	29 ³ / ₄ (756mm)
Ext. Height Overall in.	77 (1956mm)
Int. Length Overall in.	50 ¹ / ₂ (1283mm)
Int. Depth Overall in.	24 ¹ / ₈ (614mm)
Int. Height Overall in.	60 ³ / ₈ (1535mm)
Net Weight lbs.	505
Gross Weight lbs.	665

Design and specifications subject to change without notice.
Actual shipping weight may differ due to extra packing materials for product protection.
* Depth does not include 1-3/8" for glass door handles.

- **WARRANTY : 2 Year Parts and Labor Warranty**
Additional 3 Year Warranty on Compressor
- 4" swivel casters available (optional)

PLAN VIEW

(unit : inch)

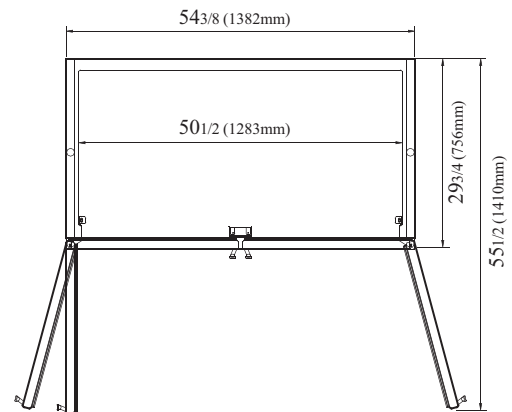

FRONT VIEW

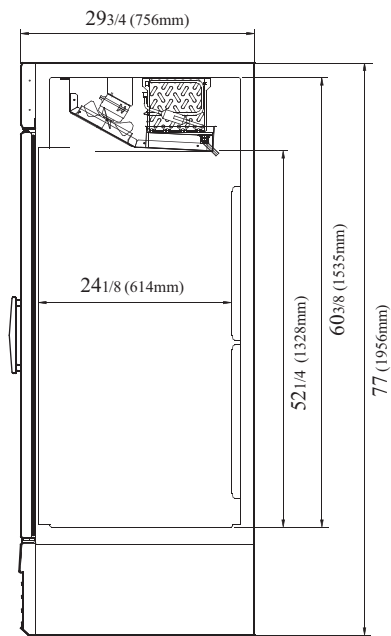

SIDE VIEW

Ver.201501



- Turbo Air : 800-627-0032
- GK : 800-500-3519
- Warranty : 800-381-7770
- AC : 888-900-1002