

REFRIGERATOR MANUFACTURER
Turbo air
 more durable, efficient, beautiful

4184 E. Conant St.
 Long Beach, CA 90808
 Tel. 310-900-1000
 Fax. 310-900-1077
www.turboairinc.com

Project :	
Model # :	
Item # :	Qty :
Available W/H :	
Approval :	

Swing Door Merchandisers

Glass Door Merchandisers
 Super Deluxe Series

Model : TGM-23SD

FEATURES & BENEFITS

- Hot gas condensate system**
 Through Turbo Air's creative innovation, the condensate system surfaces have been specially treated to resist corrosion. This not only increases efficiency without the risk of refrigerant leakage from corrosion, but also prevents the overflow of condensate water.
- Energy conserving fan control**
 Utilizing algorithmic air circulation for optimal temperature levels, our innovative fan control system conserves energy by at least 15% and increases compressor life by up to 30%.
- Turbo Cooling feature for faster chilling**
 The Turbo Cooling function, located on the control panel, allows the compressor to run continuously for up to two hours. When this function is activated, the temperature inside the cabinet quickly decreases and cools drinks, food, and other products much faster. An ideal time to use the Turbo Cooling function is when the unit is stocked with new products.
- Early warning system**
 Malfunctions are generally recognized when an increase in temperature is detected, 2 to 3 hours after the refrigerator had stopped running. This causes the user to become aware of malfunction issues the next morning in which the contents may have already spoiled. To eliminate this, Turbo Air units have a warning system in place that diagnoses and monitors itself for risk factors, which gives an early warning signal in the form of an audible alarm to eliminate product loss and future service issues.
- LED lighting interior display system**
 Brighter and longer lasting LED lights provide attractive, enhanced illumination compared to fluorescents. It saves energy by producing less heat, while maximizing the visibility in the display area.
- Shadow free advertising panel**
 Turbo Air is the pioneer in the refrigerator industry on applying special LED Light Guided Panels (LGP). LGP increases panel visibility and eliminates shadows, thus enhances any store atmosphere with eye-catching effects. LED lighting offers 10 times longer lasting life than fluorescents and conserves energy as well.
- Double pane glass doors with Low-E glass**
 Energy saving double pane glass doors are equipped with Low-emissivity glass, which reduce outer heat gain and decrease energy consumption. It enhances energy efficiency and minimizes condensation. Lightweight door construction also reduce door maintenance and bushing wear, which in turn facilitates smoother door openings.
- Door opening alarm**
 If the doors are not tightly closed, the refrigerator will not run. This would cause the cold air to escape through the opening, making food products spoil inside the cabinet. To prevent this problem, our refrigerators are equipped with the Door Alarm System that will sound if the doors are left open for more than 30 seconds.
- Digital temperature control system**
 Digital technology provides precise and constant temperatures throughout the cabinet. This allows food products to remain fresh over an extended period of time.
- High-tech monitor self-diagnosis system**
 When a refrigerator breaks, it will immediately run a self-diagnosis to figure out what the problem is, saving both service time and unnecessary expenses that could have occurred by misdiagnosis. It also allows for broken parts to be replaced easily.

3 YEAR PARTS & LABOR WARRANTY



TGM-23SDB

TGM-23SDW

TGM-23SDV

Refrigerator holds 33°F ~ 38°F for the best in beverage preservation



ENERGY STAR®
 Qualified

Model	Swing Door	CU./FT.	#of Shelves	HP	AMPS	Crated Weight (lbs.)	L x D* x H† (inches)
TGM-23SD	1	21.1	4	1/4	6.0	325	27 x 30 1/4 x 77

Model : TGM-23SD

ELECTRICAL DATA	
Voltage	115/60/1
Plug Type	Ⓜ NEMA 5-15P
Full Load Amperes	6.0
Compressor HP	1/4
Cord Length ft.	7
Refrigerant	R-134A
DIMENSIONAL DATA	
# of Doors	1
Net Capacity cu. ft.	21.1
Ext. Length Overall in.	27 (685mm)
Ext. Depth Overall in.*	30 1/4 (770mm)
Ext. Height Overall in.†	77 (1955mm)
Int. Length Overall in.	23 (585mm)
Int. Depth Overall in.	25 3/4 (655mm)
Int. Height Overall in.	60 3/8 (1535mm)
Net Weight lbs.	304
Gross Weight lbs.	325
# of Shelves	4
Shelf Size (LxD) in.	21 3/4 x 22 1/2

Design and specifications subject to change without notice.
Actual shipping weight may differ due to extra packing materials for product protection.
* Depth does not include 2-1/4" (57mm) for door handle.
† Height does not include 2-1/2" (63mm) for leg height.

■ **WARRANTY : 3 Year Parts and Labor Warranty
Additional 2 Year Warranty on Compressor**

- High-tech monitor self-diagnosis system
- High-density polyurethane insulation
- Door locking system standard
- Price tag channel available (optional)
- Optional 4" casters available - 1/2" diameter & 13 TPI
- Three color options available (standard) :
Super Deluxe series comes in white cabinet (W),
white cabinet with wine color trim (V)
or black cabinet with black color trim (B).

PLAN VIEW

(unit : inch)

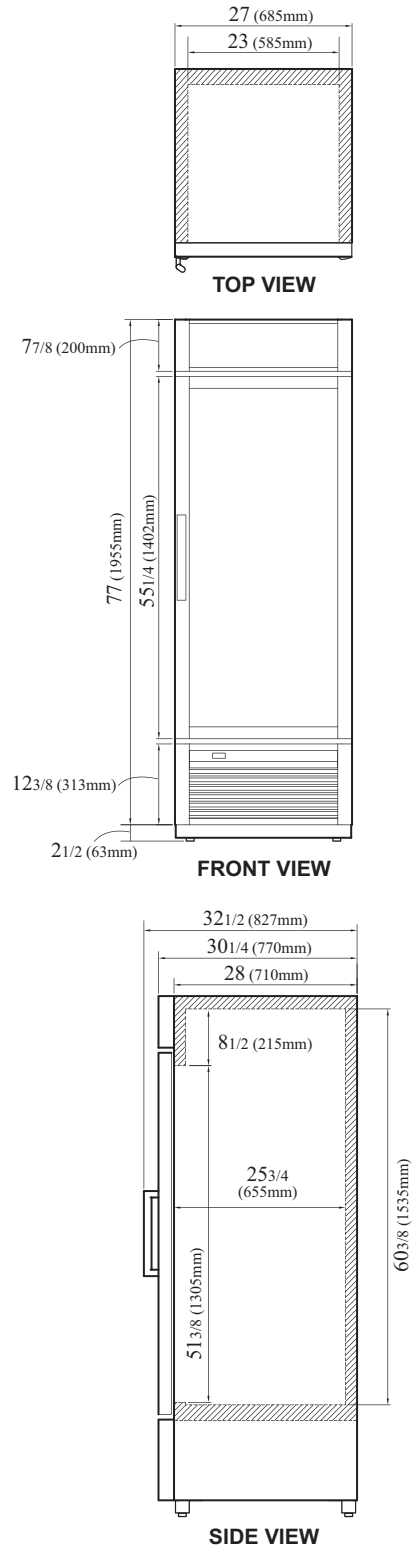

Ver.201501



ENERGY STAR®
Qualified

- Turbo Air : 800-627-0032
- GK : 800-500-3519
- Warranty : 800-381-7770
- AC : 888-900-1002

