

REFRIGERATOR MANUFACTURER
Turbo air
 more durable, efficient, beautiful

4184 E. Conant St.
 Long Beach, CA 90808
 Tel. 310-900-1000
 Fax. 310-900-1077
www.turboairinc.com

Project :	
Model # :	
Item # :	Qty :
Available W/H :	
Approval :	

Glass / Mug Chillers

*Underbar Equipment
 Super Deluxe Series*

**3 YEAR PARTS & LABOR
 WARRANTY**

Model : TBC-36SD/SB-GF



TBC-36SD-GF



TBC-36SB-GF

≡ FEATURES & BENEFITS ≡

▪ **Efficient refrigeration system**

Turbo Air's refrigerators are designed with oversized and balanced R-134A or R-404A (CFC Free) refrigeration systems. These include efficient evaporators and condensers for faster cooling and greater efficiency.

▪ **Forced air cooling system**

Positive guided forced air cooling system chills dry glasses & plates fast throughout the cabinet.

▪ **Stainless steel cabinet construction**

Super Deluxe (SD) models boast a stainless steel exterior (except galvanized steel back and bottom). SB models are attractive wear-resistant black vinyl exterior. Heavy gauge stainless steel countertop and glide lids are perfect for sanitation and durability. Interior is stainless steel except galvanized steel top. Turbo Air glass chiller model guarantees utmost in cleanliness and long product life. It also can add a touch of style to the most refined setting.

▪ **High-density polyurethane insulation**

The entire cabinet structure is foamed-in-place using high density, CFC free polyurethane insulation.

▪ **Heavy duty, PE(Polyethylene) coated shelves**

Heavy duty 10mm thick pure grade PE coated adjustable bin dividers are provided for maximum storage use.

▪ **Side mount compressor unit**

By positioning the compressor on the side of the unit, refrigerators can now be serviced without being moved. Our innovative, front breathing feature also allows this model to provide high efficiency in narrow spaces.

▪ **Huge capacity cooler cabinet requires only minimum floor space**

▪ **Glass / mug chiller holds 5°F ~ -5°F for the best in chilling glasses and plates**



Model	Sliding Door	CU./FT.	Capacity 8" Mug / 10oz Stein	# of Shelves	HP	AMPS	Crated Weight (lbs.)	L x D* x H† (inches)
TBC-36SD-GF	1	8	93 / 227	5	1/4	4.0	230	363/4 x 261/2 x 331/4
TBC-36SB-GF	1	8	93 / 227	5	1/4	4.0	230	363/4 x 261/2 x 331/4

Model : TBC-36SD/SB-GF

ELECTRICAL DATA	
Voltage	115/60/1
Plug Type	Ⓜ NEMA 5-15P
Full Load Amperes	4.0
Compressor HP	1/4
Refrigerant	R-134A
Cord Length (ft.)	8.5
DIMENSIONAL DATA	
Capacity (8" Mug / 10oz Stein)	93 / 227
Net Capacity cu. ft.	8
Ext. Length Overall in.	36 ³ / ₄ (933mm)
Ext. Depth Overall in.*	26 ¹ / ₂ (673mm)
Ext. Height Overall in.†	33 ¹ / ₄ (845mm)
Net Weight lbs.	200
Gross Weight lbs.	230
# of Shelves	5

Design and specifications are subject to change without notice.
Actual shipping weight may differ due to extra packing materials for product protection.
* Depth does not include 2" for cap catcher or 2" for rear spacers.
† Height does not include 5" for 4" swivel caster height.

■ **WARRANTY : 3 Year Parts and Labor Warranty**
Additional 2 Year Warranty on Compressor

- **Self-contained system**
- **4" swivel casters standard**
- **2" casters available (optional)**
- **6" adjustable legs available (optional)**

PLAN VIEW

(unit : inch)

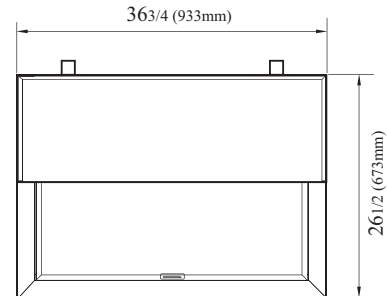

PLAN VIEW

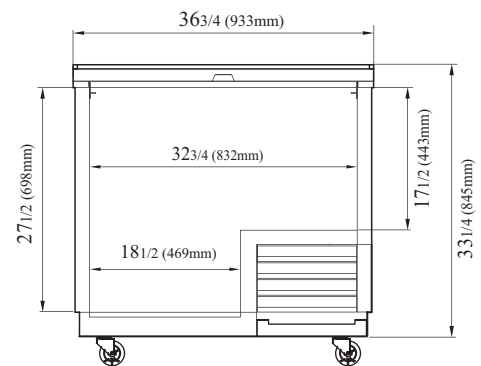

FRONT VIEW

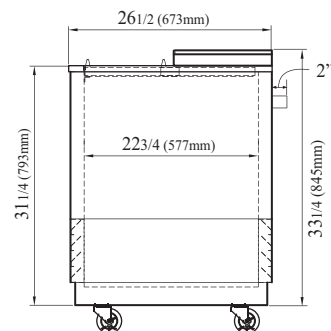

SIDE VIEW

Ver.201501



- Turbo Air : 800-627-0032
- GK : 800-500-3519
- Warranty : 800-381-7770
- AC : 888-900-1002