

**REFRIGERATOR MANUFACTURER**  
**Turbo air**  
 more durable, efficient, beautiful

4184 E. Conant St.  
 Long Beach, CA 90808  
 Tel. 310-900-1000  
 Fax. 310-900-1077  
[www.turboairinc.com](http://www.turboairinc.com)

Project :	
Model # :	
Item # :	Qty :
Available W/H :	
Approval :	

## Undercounter Freezer

Undercounters  
**M3 Series**

**3 YEAR PARTS & LABOR WARRANTY**

**Model : MUF-36**



### ≡ FEATURES & BENEFITS ≡

- Stainless steel cabinet construction**  
 The Turbo Air M3 model boasts a stainless steel exterior (galvanized steel back and bottom). Interior is stainless steel floor with AL sides and back. It guarantees the utmost in cleanliness and long product life. It can add a touch of style to the most refined setting.
- Efficient refrigeration system**  
 M3's solid door freezers are designed with oversized and balanced (CFC Free R-134A, R-404A) refrigeration systems. These include efficient evaporators and condensers for faster freezing and greater efficiency.
- High-density polyurethane insulation**  
 The entire cabinet structure and solid doors are foamed-in-place using high density, CFC free polyurethane insulation.
- Adjustable, heavy duty, PE (polyethylene) coated wire shelves**
- Ergonomically designed doors**  
 Customers' fatigue fades away with easy grip handles and doors that open effortlessly. These features along with self-closing doors make this the ultimate choice in customer convenience. ABS sheet door liners resist water condensation with thermal efficiency.
- Magnetic door gaskets**  
 Magnetic door gaskets are of one piece construction, removable without tools for ease of cleaning and replacement.
- Freezer holds 0°F ~ -10°F for the best in frozen food preservation**



Model	Swing Door	CU./FT.	#of Shelves	HP	AMPS	Crated Weight (lbs.)	L x D* x H† (inches)
<b>MUF-36</b>	<b>2</b>	<b>9.2</b>	<b>2</b>	<b>1/3</b>	<b>6</b>	<b>187</b>	<b>36 1/4 x 30 x 30 5/8</b>

## Model : MUF-36

ELECTRICAL DATA	
Voltage	115/60/1
Plug Type	Ⓜ NEMA 5-15P
Full Load Amperes	6.0
Compressor HP	1/3
Cord Length ft.	9
Refrigerant	R-134A
DIMENSIONAL DATA	
Net Capacity cu. ft.	9.2
Ext. Length Overall in.	36 1/4 (921mm)
Ext. Depth Overall in.*	30 (762mm)
Ext. Height Overall in.†	30 5/8 (777mm)
# of Doors	2
# of Shelves	2
Net Weight lbs.	160
Gross Weight lbs.	187

Design and specifications subject to change without notice.  
Actual shipping weight may differ due to extra packing materials for product protection.  
\* Depth does not include 1" for rear spacers.  
† Height does not include 5-7/8" for caster height.

■ **WARRANTY : 3 Year Parts and Labor Warranty**  
Additional 2 Year Warranty on Compressor

- **Self-contained system**
- **Standard 4" swivel casters with locks on the front set**
- **Legs available for all models (optional)**
- **Stainless steel double overshef available (optional)**
- **Door locks available (optional)**
- **External digital thermometer available (optional)**
- **2.5" dia. casters available (optional) - 1/2" diameter & 13 TPI**

■ **OPTIONAL ACCESSORIES :**

- 2.5" Diameter casters
- 5" Diameter casters
- 6" ABS plastic legs
- Additional stainless steel shelves
- Additional PE coated wire shelves
- Back splash guard
- Stainless steel double over-shelf

## PLAN VIEW

(unit : inch)

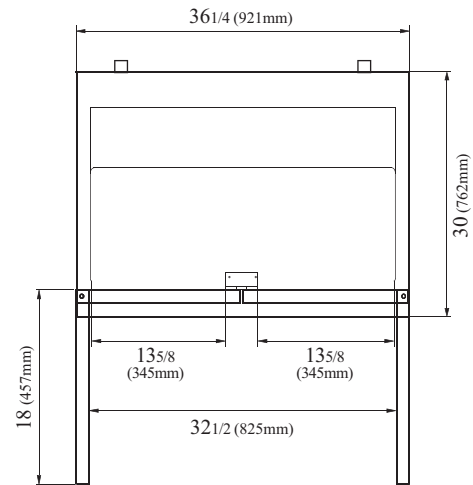

PLAN VIEW

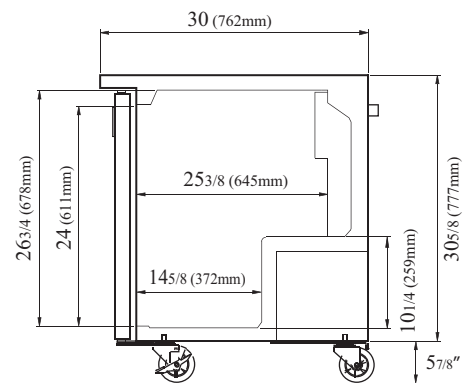

SIDE VIEW

Ver.201501



- Turbo Air : 800-627-0032
- GK : 800-500-3519
- Warranty : 800-381-7770
- AC : 888-900-1002