

REFRIGERATOR MANUFACTURER
Turbo air
 more durable, efficient, beautiful

4184 E. Conant St.
 Long Beach, CA 90808
 Tel. 310-900-1000
 Fax. 310-900-1077
www.turboairinc.com

Project :
 Model # :
 Item # : Qty :
 Available W/H :
 Approval :

Chef Base (Extended Top)

*Chef Bases
 Super Deluxe Series*

**3 YEAR PARTS & LABOR
 WARRANTY**

**Model : TCBE-48SDR
 TCBE-48SDR-E**



- Each drawer accommodates up to 4" deep sixth (1/6) size pans (drawer pans not included)

≡ FEATURES & BENEFITS ≡

- Strong body and durable construction**
 Built with heavy duty, 304 stainless steel (16 gauges) Chef Base top is manufactured of one-piece reinforced stainless steel to ensure durability.
- Drawers**
 Small drawer holds up to 154 pounds.
 Large drawer holds up to 242 pounds.
- Countertops**
 TCBE-36 / 48 / 52SDR support up to 788 pounds of equipment.
 TCBE-72 / 82SDR support up to 1,192 pounds of equipment.
 TCBE-96SDR supports up to 1,435 pounds of equipment.
- Durable stainless steel drawers**
- Top is insulated to eliminate heat transfer to the interior of cabinet**
- Efficient refrigeration system**
 Turbo Air's solid door refrigerators are designed with oversized and balanced (CFC Free R-134A) refrigeration systems. These include efficient evaporators and condensers for faster cooling and greater efficiency.
- Side mount compressor unit**
 By positioning the compressor on the side of the unit, refrigerators can now be serviced without being moved. Our innovative, front breathing feature also allows this model to provide high efficiency in narrow spaces.
- High-density polyurethane insulation**
 The entire cabinet structure and solid doors are foamed-in-place using high density, CFC free polyurethane insulation.
- Refrigerator holds 33°F ~ 38°F for the best in food preservation**



Model	Drawers	CU./FT.	Countertop Weight Capacity (lbs.)	HP	AMPS	Crated Weight (lbs.)	L x D x H* (inches)
TCBE-48SDR	2	9.2	788	1/4	3	284	47 5/8 x 32 x 20 1/2
TCBE-48SDR-E	2	9.2	788	1/4	3	304	53 5/8 x 32 x 20 1/2

ELECTRICAL DATA	TCBE-48SDR	TCBE-48SDR-E
Voltage	115/60/1	115/60/1
Plug Type	Ⓜ NEMA 5-15P	Ⓜ NEMA 5-15P
Full Load Amperes	3	3
Compressor HP	1/4	1/4
Cord Length ft.	9	9
Refrigerant	R-134A	R-134A
DIMENSIONAL DATA		
Ext. Length Overall in.	47 ⁵ / ₈ (1209mm)	53 ⁵ / ₈ (1361mm)
Ext. Depth Overall in.	32 (813mm)	32 (813mm)
Ext. Height Overall in.*	20 ¹ / ₂ (521mm)	20 ¹ / ₂ (521mm)
# of Drawers	2	2
# of Pans	30	30
Net Capacity cu. ft.	9.2	9.2
Net Weight lbs	218	240
Gross Weight lbs..	284	304

Design and specifications subject to change without notice.
Actual shipping weight may differ due to extra packing materials for product protection.
* Height does not include 5-7/8" for caster height.

■ **WARRANTY : 3 Year Parts and Labor Warranty
Additional 2 Year Warranty on Compressor**

- **Self-contained system**
- **5" swivel casters**
- **Legs available for all models (optional)**
- **Door locks available (optional)**

PLAN VIEW

(unit : inch)

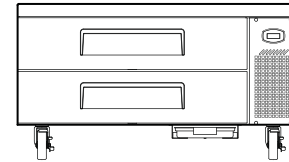

FRONT VIEW

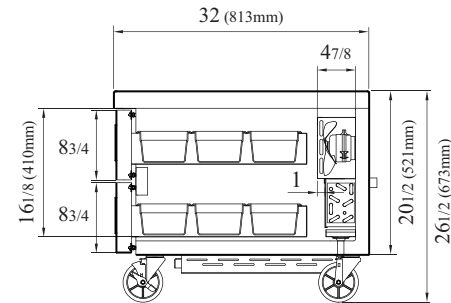

SIDE VIEW

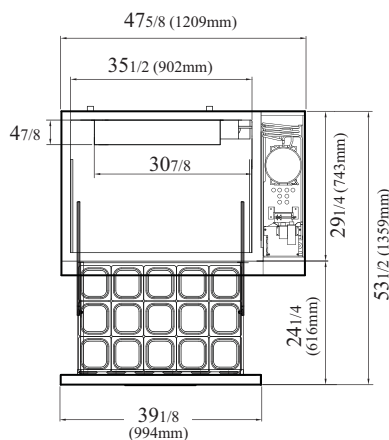

PLAN VIEW

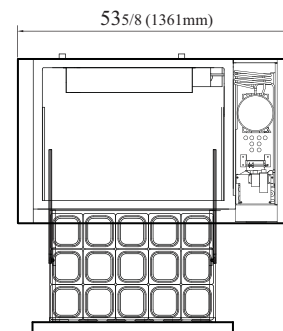

EXTENDED TOP PLAN VIEW

Ver.201501



- Turbo Air : 800-627-0032
- GK : 800-500-3519
- Warranty : 800-381-7770
- AC : 888-900-1002