

REFRIGERATOR MANUFACTURER
Turbo air
 more durable, efficient, beautiful

4184 E. Conant St.
 Long Beach, CA 90808
 Tel. 310-900-1000
 Fax. 310-900-1077
www.turboairinc.com

Project :	
Model # :	
Item # :	Qty :
Available W/H :	
Approval :	

Buffet Display Table

Food Prep Tables
 J Series

Model : JBT-36



Click here to buy now!

Central
 RESTAURANT PRODUCTS

1-866-285-1252

≡ FEATURES & BENEFITS ≡

■ **Hot gas condensate system**

Through Turbo Air's creative innovation, the condensate system surfaces have been specially treated to resist corrosion. This not only increases efficiency without the risk of refrigerant leakage from corrosion, but also prevents the overflow of condensate water.

■ **Side mount compressor unit**

By positioning the compressor on the side of the unit, refrigerators can now be serviced without being moved. Our innovative, front breathing feature also allows this model to provide high efficiency in narrow spaces.

■ **Efficient refrigeration system**

Turbo Air J series refrigerators are designed with oversized and balanced (CFC Free R-134A) refrigeration systems. These include efficient evaporators and condensers for faster cooling and greater efficiency.

■ **Exterior & interior of the cabinet**

The Turbo Air J series boasts a stainless steel exterior (galvanized steel back and bottom). Interior is stainless steel floor with AL sides, back and AL door liners. It guarantees the utmost in cleanliness and long product life. It can add a touch of style to the most refined setting.

■ **High-density polyurethane insulation**

The entire cabinet structure and solid doors are foamed-in-place using high density, CFC free polyurethane insulation.

■ **Magnetic door gaskets**

Magnetic door gaskets are of one piece construction, removable without tools for ease of cleaning and replacement.

■ **Adjustable, heavy duty, PE(polyethylene) coated wire shelves**

■ **Ergonomically designed doors**

Customers' fatigue fades away with easy grip handles and doors that open effortlessly. These features along with self-closing doors make this the ultimate choice in customer convenience.

■ **Refrigerator holds 33°F ~ 39°F for the best in food preservation**



Model	Swing Door	CU./FT.	#of Shelves	#of Pans (1/3)	HP	AMPS	Crated Weight (lbs.)	L x D x H* (inches)
JBT-36	1	7.5	1	6	1/4	6.6	171	353/8 x 271/2 x 283/4

Buffet Display Table

Food Prep Tables
J Series

Model : JBT-36

ELECTRICAL DATA	
Voltage	115/60/1
Plug Type	Ⓜ NEMA 5-15P
Full Load Amperes	6.6
Compressor HP	1/4
Cord Length ft.	9.2
Refrigerant	R-134A
DIMENSIONAL DATA	
Ext. Length Overall in.	35 ³ / ₈ (899mm)
Ext. Depth Overall in.	27 ¹ / ₂ (698mm)
Ext. Height Overall in.*	28 ³ / ₄ (730mm)
# of Doors	1
# of Shelves	1
# of Pans	6
Net Capacity cu. ft.	7.5
Net Weight lbs.	152
Gross Weight lbs.	171

Design and specifications subject to change without notice.
Actual shipping weight may differ due to extra packing materials for product protection.
* Height does not include 5-7/8" for caster height.

- **WARRANTY : 2 Year Parts and Labor Warranty
Additional 3 Year Warranty on Compressor**
- **Self-contained system**
- **Standard 4" swivel casters with locks on the front set**
- **1/3 size condiment pan included**
- **2.5" dia. casters available (optional) - 1/2" diameter & 13 TPI**
- **Door locks available (optional)**
- **Legs available for all models (optional)**
- **Sneeze guard available (optional)**
- **Tray slide available (optional)**
- **Clear pan cover available (optional)**

PLAN VIEW

(unit : inch)

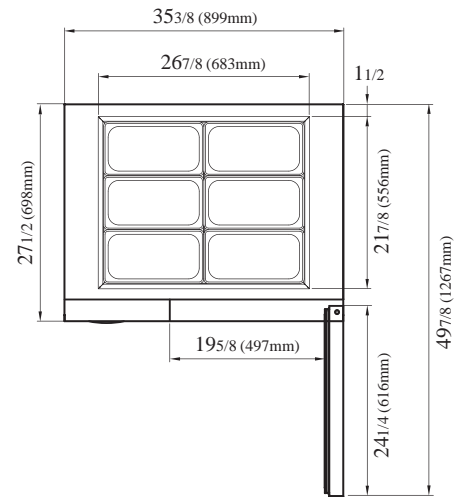

PLAN VIEW

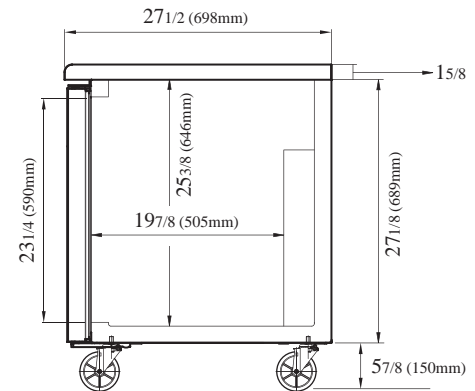

SIDE VIEW

■ Tray Slide & Clear Pan Cover (Optional)

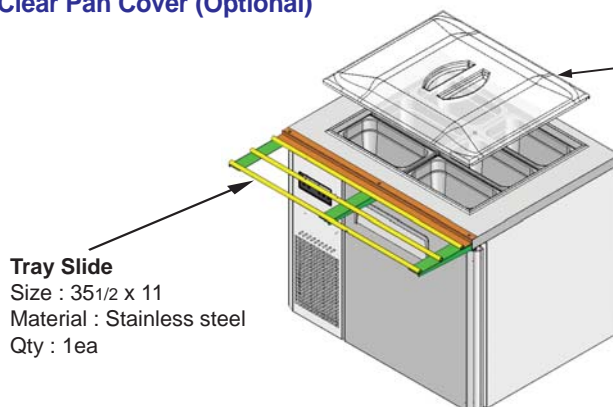

Tray Slide
Size : 35¹/₂ x 11
Material : Stainless steel
Qty : 1ea

Clear Pan Cover
Size : 27³/₈ x 22¹/₂
Material : Clear PC (Polycarbonate) Plastic
Qty : 1ea



Ver.201501



- Turbo Air : 800-627-0032
- GK : 800-500-3519
- Warranty : 800-381-7770
- AC : 888-900-1002

REFRIGERATOR MANUFACTURER
Turbo air

GERMAN KNIFE

RADIANCE

GREEN WORLD

AIR CONDITIONER MANUFACTURER
Turbo air