

REFRIGERATOR MANUFACTURER
Turbo air
 more durable, efficient, beautiful

4184 E. Conant St.
 Long Beach, CA 90808
 Tel. 310-900-1000
 Fax. 310-900-1077
www.turboairinc.com

Project :	
Model # :	
Item # :	Qty :
Available W/H :	
Approval :	

Undercounter Refrigerator - Narrow

Side Mount Undercounters
 J Series

Model : JUR-72N



≡ FEATURES & BENEFITS ≡

■ Hot gas condensate system

Through Turbo Air's creative innovation, the condensate system surfaces have been specially treated to resist corrosion. This not only increases efficiency without the risk of refrigerant leakage from corrosion, but also prevents the overflow of condensate water.

■ Side mount compressor unit

By positioning the compressor on the side of the unit, refrigerators can now be serviced without being moved. Our innovative, front breathing feature also allows this model to provide high efficiency in narrow spaces.

■ Efficient refrigeration system

Turbo Air J series refrigerators are designed with oversized and balanced (CFC Free R-134A) refrigeration systems. These include efficient evaporators and condensers for faster cooling and greater efficiency.

■ Exterior & interior of the cabinet

The Turbo Air J series boasts a stainless steel exterior (galvanized steel back and bottom). Interior is stainless steel floor with AL sides, back and AL door liners. It guarantees the utmost in cleanliness and long product life. It can add a touch of style to the most refined setting.

■ High-density polyurethane insulation

The entire cabinet structure and solid doors are foamed-in-place using high density, CFC free polyurethane insulation.

■ Magnetic door gaskets

Magnetic door gaskets are of one piece construction, removable without tools for ease of cleaning and replacement.

■ Adjustable, heavy duty, PE (polyethylene) coated wire shelves

■ Ergonomically designed doors

Customers' fatigue fades away with easy grip handles and doors that open effortlessly. These features along with self-closing doors make this the ultimate choice in customer convenience.

■ Refrigerator holds 33°F ~ 39°F for the best in food preservation



Model	Swing Door	CU./FT.	#of Shelves	HP	AMPS	Crated Weight (lbs.)	L x D* x H† (inches)
JUR-72N	3	14.7	3	1/4	4.8	240	707/8 x 235/8 x 283/4

Model : JUR-72N

ELECTRICAL DATA	
Voltage	115/60/1
Plug Type	ⓘ NEMA 5-15P
Full Load Amperes	4.8
Compressor HP	1/4
Cord Length ft.	9.85
Refrigerant	R-134A
DIMENSIONAL DATA	
Net Capacity cu. ft.	14.7
Ext. Length Overall in.	70 ⁷ / ₈ (1800mm)
Ext. Depth Overall in.*	23 ⁵ / ₈ (600mm)
Ext. Height Overall in.†	28 ³ / ₄ (730mm)
# of Doors	3
# of Shelves	3
Net Weight lbs.	205
Gross Weight lbs.	240

Design and specifications subject to change without notice.
Actual shipping weight may differ due to extra packing materials for product protection.
* Depth does not include 1" for rear spacers.
† Height does not include 5-7/8" for caster height.

■ **WARRANTY : 2 Year Parts and Labor Warranty
Additional 3 Year Warranty on Compressor**

- **Self-contained system**
- **Standard 4" swivel casters with locks on the front set**
- **2.5" dia. casters available - 1/2" diameter & 13 TPI (optional)**
- **Door locks available (optional)**
- **Legs available for all models (optional)**

■ **OPTIONAL ACCESSORIES :**

- 2.5" Diameter casters
- 6" ABS plastic legs
- Additional PE coated wire shelves

PLAN VIEW

(unit : inch)

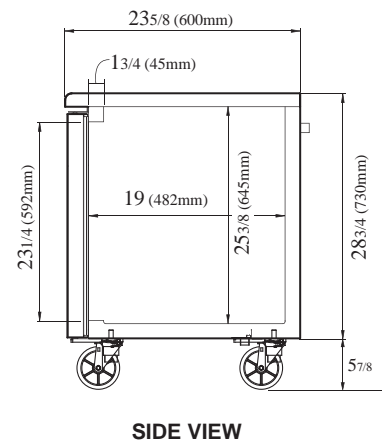
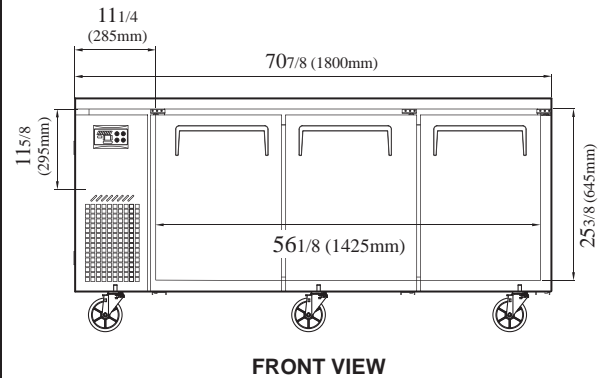
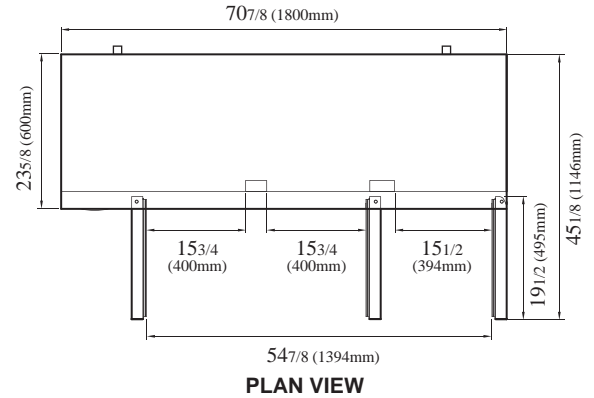

Ver.201504



- Turbo Air : 800-627-0032
- GK : 800-500-3519
- Warranty : 800-381-7770
- AC : 888-900-1002