

Click here to buy now!

Central[®]
RESTAURANT PRODUCTS
WHOLESALE EQUIPMENT & SUPPLIES

Model LS-1 Series

Anodized Aluminum Portable Vacuum Filter Machine

1-866-285-1252

Use with the SuperSorb[®] CarbonPad for maximum frying oil purification

Description

Filtering of frying fats and oils has been recognized by the food service industry as a necessary procedure to maximize an oil's fry-life and to maintain acceptable fried food quality. Most of the food particles that speed the oil's breakdown are sub-micron in size; as a result, they continue to accumulate and circulate in the oil despite traditional filtering. Nylon mesh baskets and Paper and Powder methods offer little more than crumb removal. Therefore, there is limited effective counteraction to the oil breakdown process.

Filtercorp's Model LS-1 60# and 100# filter machines are constructed of Anodized Aluminum. Anodizing provides a reacted finish that is integrated with the underlying aluminum for a total bonding and unmatched adhesion. This process imparts strength only second in hardness to diamonds, allowing units to withstand everyday wear. Anodizing is a safe process that is not harmful to human health. The finish is chemically stable, will not decompose and is non-toxic.

Filtercorp's Model LS-1 60# and 100# filter machines utilize the SuperSorb[®] CarbonPad. The SuperSorb[®] CarbonPad is an easy-to-use depth filter media used for treatment of edible frying oil. It is a packaging of activated carbon, filter aids and cellulose fibers. By uniquely adding each ingredient under controlled manufacturing practices, a uniform matrix results that achieves superior filtration. SuperSorb[®] CarbonPads remove critical particulate contamination from edible fry oils during the filtration process, down to the nominal range of 0.5 microns.

A filter machine's effectiveness is based on the filter media used. The LS-1 SERIES Filter Machine incorporates the finest filtering media in the industry.



Main Features

- Increased durability
- Reduced weight
- Ease of maintenance
- Simple to operate
- Removable pan for easy cleaning
- Sturdy construction and high quality finish
- Safety no-splash nozzle
- Compact for easy storage
- Uses SuperSorb[®] CarbonPad for improved filtration compared to traditional filter media
- One-piece CarbonPad holder is easier to use than paper holders and powder additives
- Patented CarbonPad holder provides positive seal so all oil must pass through the CarbonPad

 **FILTERCORP**
*Bottom line,
Your Proven Profit Multiplier.*



*Bottom line,
Your Proven Profit Multiplier.*

Model LS-1 Series Dimensions and Specifications

Dimensions for LS-1-60

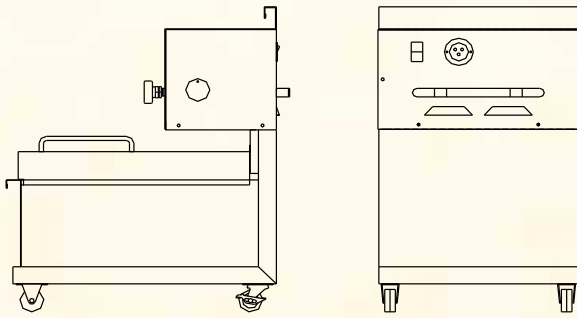

Weight	64 Lbs.
Overall Dimensions	16.75" wide x 23.75" deep x 27.25" high
Pan Height	11.75"
Total Pan Capacity	1.63 cubic feet or 12.1 gallons
Oil Capacity	60 Lbs. of oil or 7.7 gallons
Pump/Motor	Haight SE Hot Oil Hub Mount Pump, Capacity: 4.6 GPM at 1750 RPM, 1/3 HP Capacitor Start, Rotary Gear, Positive Displacement Pump, 115 Volt, 6.2 Amperes, 60-Cycle Motor
Electrical Plug Material	Standard 3 wire, 110 Volt Plug-In Cord (12 feet in length) 0.090 Anodized Aluminum

Dimensions for LS-1-100

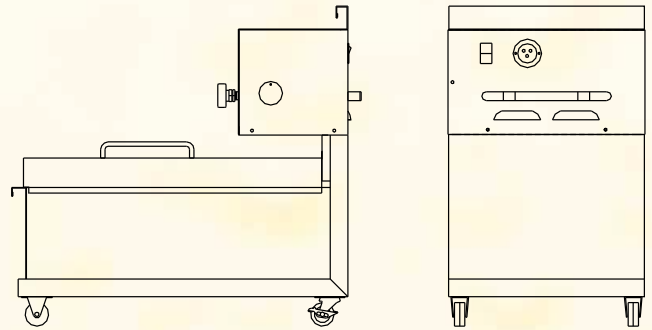

Weight	83.5 Lbs.
Overall Dimensions	16.75" wide x 33.5" deep x 27.25" high
Pan Height	11.75"
Total Pan Capacity	2.52 cubic feet or 18.7 gallons
Oil Capacity	115 Lbs. of oil or 14.7 gallons
Pump/Motor	Haight SE Hot Oil Hub Mount Pump, Capacity: 4.6 GPM at 1750 RPM, 1/3 HP, Capacitor Start, Rotary Gear, Positive Displacement Pump, 115 volt, 6.2 Amperes, 60-Cycle Motor
Electrical Plug Material	Standard 3 wire, 110 Volt Plug-In Cord (12 feet in length) 0.090 Anodized Aluminum



9805 NE 116th Street
PMB A-200
Kirkland, WA 98034
USA

Toll Free: (800) 473-4526
Telephone: (425) 820-4850
Fax: (425) 820-2816
Web: www.filtercorp.com



www.filtercorp.com