



Project:

Item Number:

Quantity:

HEAVY-DUTY STATIONARY AND MOBILE EQUIPMENT STANDS

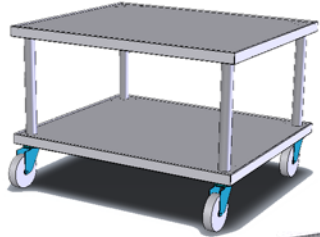

4087936

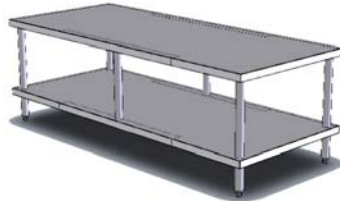

4087060

Heavy-Duty Equipment Stands

DESCRIPTION

Vollrath's heavy-duty stainless steel equipment stands, available in either stationary or mobile configurations, are designed to support the weight of heavy-duty appliances.

MODELS

- 4087024 Stationary Stand – 24" width
- 4087036 Stationary Stand – 36" width
- 4087048 Stationary Stand – 48" width
- 4087060 Stationary Stand – 60" width
- 4087072 Stationary Stand – 72" width
- 4087924 Mobile Stand – 24" width
- 4087936 Mobile Stand – 36" width
- 4087948 Mobile Stand – 48" width
- 4087960 Mobile Stand – 60" width
- 4087972 Mobile Stand – 72" width

FEATURES

- Stainless steel top and undershelf
- Available with 5" (12.7 cm) casters for mobility or 1" (2.5 cm) adjustable feet for stability
- Mobile stands include a tethering-restraint kit to tether the table to the wall
- 60" and 72" stands include center supports to ensure sturdy, level work areas across the entire width of the stand
- Tops and bottom shelves feature a marine edge
- Ships knocked down; ready to assemble

WARRANTY: All models shown come with Vollrath's standard warranty against defects in materials and workmanship. For full warranty details, please refer to the Vollrath Equipment and Smallwares Catalog.

Agency Listings



Due to continued product improvement, please consult www.vollrathco.com for current product specifications.

Approvals	Date



Setting the Standard™

www.vollrathco.com

The Vollrath Company, L.L.C.
 1236 North 18th Street
 Sheboygan, WI 53081-3201 U.S.A.
 Customer Service: 800.628.0830
 Canada Customer Service: 800.695.8560
 Main Fax: 800.752.5620 or 920.459.6573

Technical Services: 800.628.0832
 Technical Services Fax: 920.459.5462

HEAVY-DUTY STATIONARY AND MOBILE EQUIPMENT STANDS

MODELS	4087024 Stationary Stand – 24" width	4087924 Mobile Stand – 24" width
	4087036 Stationary Stand – 36" width	4087936 Mobile Stand – 36" width
	4087048 Stationary Stand – 48" width	4087948 Mobile Stand – 48" width
	4087060 Stationary Stand – 60" width	4087960 Mobile Stand – 60" width
	4087072 Stationary Stand – 72" width	4087972 Mobile Stand – 72" width

DIMENSIONS

Dimensions shown in inches (cm).

Stationary Cart

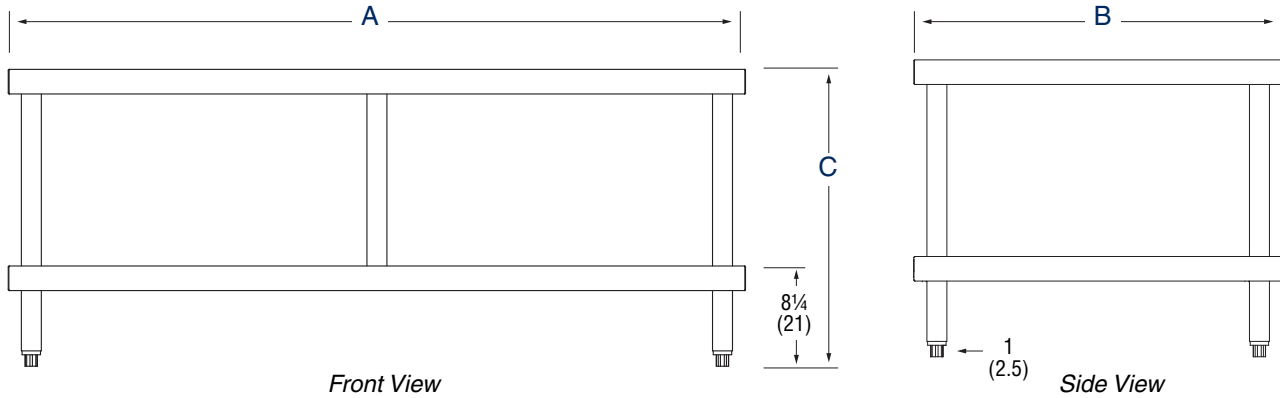

Note: Center support only on 60" and 72" stands

Mobile Cart

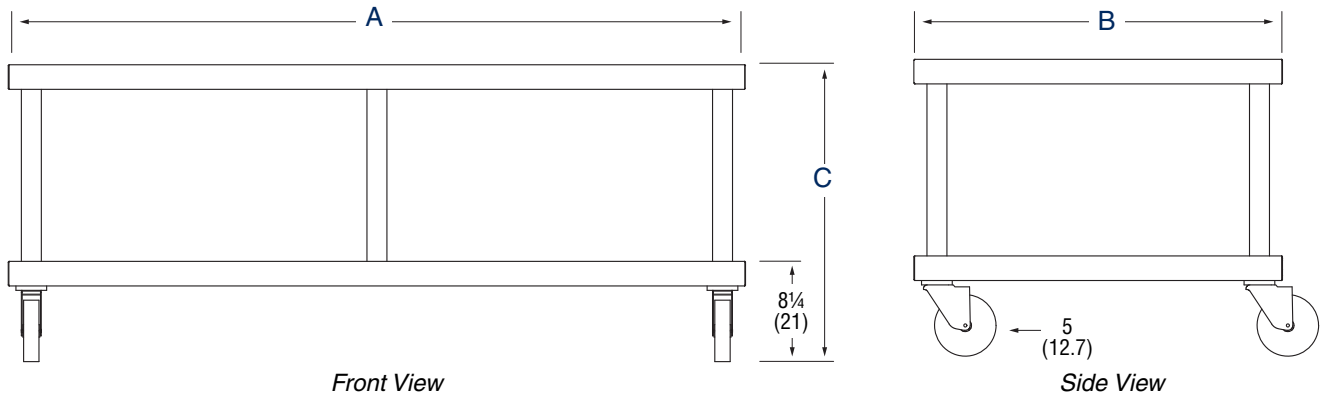

SPECIFICATIONS

Item	Capacity LB (kg)	Overall Dimensions		
		(A) Width	(B) Depth	(C) Height
4087024	500 (226.8)	24 (61)	30 (76.2)	24 (61)
4087036	550 (249.5)	36 (91.4)		
4087048	600 (272.2)	48 (121.9)		
4087060	650 (294.8)	60 (152.4)		
4087072	700 (317.5)	72 (182.9)		

Item	Capacity LB (kg)	Overall Dimensions		
		(A) Width	(B) Depth	(C) Height
4087924	500 (226.8)	24 (61)	30 (76.2)	24 (61)
4087936	550 (249.5)	36 (91.4)		
4087948	600 (272.2)	48 (121.9)		
4087960	650 (294.8)	60 (152.4)		
4087972	700 (317.5)	72 (182.9)		



The Vollrath Company, L.L.C.
 1236 North 18th Street
 Sheboygan, WI 53081-3201 U.S.A.
 Customer Service: 800.628.0830
 Canada Customer Service: 800.695.8560
 Main Fax: 800.752.5620 or 920.459.6573

Technical Services: 800.628.0832
 Technical Services Fax: 920.459.5462