



The Signature of Quality

FEDERAL INDUSTRIES

A Standex Company

215 Federal Avenue
Belleville, Wisconsin 53508-9201

Phone: 800-356-4206

Fax: 608-424-3234

Email: Geninfo@Federalind.com

Website: Federalind.com

Project Name: _____

Item #: _____

Model #: _____ Qty: _____

Approval: _____

AIA #

SIS #

High Profile Self-Serve Heated Merchandiser – 60”H x 35”D

Designed for customers looking to increase grab and go sales of hot packaged products or to complement refrigerated offering.



Model HSSM360 Shown with custom rear sliding doors, LED lights below shelves and reflective end glass

MODEL	DIMENSIONS (Includes End Panels)
<input type="checkbox"/> HSSM260	24.1 x 35.2 x 60.6 (in) 612 x 894 x 1539 (mm)
<input type="checkbox"/> HSSM360	36.1 x 35.2 x 60.6 (in) 917 x 894 x 1539 (mm)
<input type="checkbox"/> HSSM460	48.1 x 35.2 x 60.6 (in) 1217 x 894 x 1539 (mm)

STANDARD FEATURES

Model Features

- Matches design/style of the RSSM “curved” sided refrigerated merchandiser
- Independently controlled heated shelves for different menu items
- Stainless steel heated display deck, stainless steel interior sides and back panel
- Top LED light for maximum merchandising appeal and long life
- Customized laminates for matching décor with choice of six standard laminates on exterior
- Powder coated painted base frame
- Tempered glass end inserts with choice of six standard color laminates on exterior. Black standard.

Heating System

- Easy front access microprocessor digital temperature controls
- Individually heated shelves that are easily adjusted or replaced
- Holds product up to average temperature of 160°F (71°C)

Shelving

- Three heated tiers of adjustable stainless-steel shelves with price tag rails on 1 5/8” centers. Shelves can be flat or slanted downwards at 10°
- One removable heated deck below bottom shelf

Lighting

- 3500K LED Top Light
- DLC certified, IP 66 rated

Base

- Leg levelers
- (6’/1829mm) Cord and plug

Agency Approvals

- UL and NSF

OPTIONAL ACCESSORIES

- | | |
|---|---|
| <input type="checkbox"/> Special Exterior Laminate Finish | <input type="checkbox"/> Legs, 6" (152mm) |
| <input type="checkbox"/> Solid Right/Left End Panels (mirrored) | <input type="checkbox"/> Front Cart Bumper - Stainless Steel Exterior |
| <input type="checkbox"/> Reflective End Glass | <input type="checkbox"/> Reflective or Clear Rear Loading Doors |
| <input type="checkbox"/> 2 ½" (63.5 mm) or 4" (101.6mm) Casters | <input type="checkbox"/> LED Lights Below Shelves |
| | <input type="checkbox"/> Replacement Shelves and Deck |

*Additional options available on the website and price list.



WARRANTY*
One year Parts and Labor
(U.S.A. and Canada)

Note: Information is subject to change at any time. Visit www.federalind.com for the most current specs.

AIA #	<h1>High Profile Self-Serve Heated Merchandiser – 60”H x 35”D</h1>
SIS #	<h2>Product Specifications</h2>

Intended Product to Be Displayed - Packaged heated product.	Warmest Avg Prod Temp °F/°C
	160°F/[71.1C]

DIMENSION: xx"/(mm)
DIMENSION TOLERANCE +/- 0.25 (6.4)

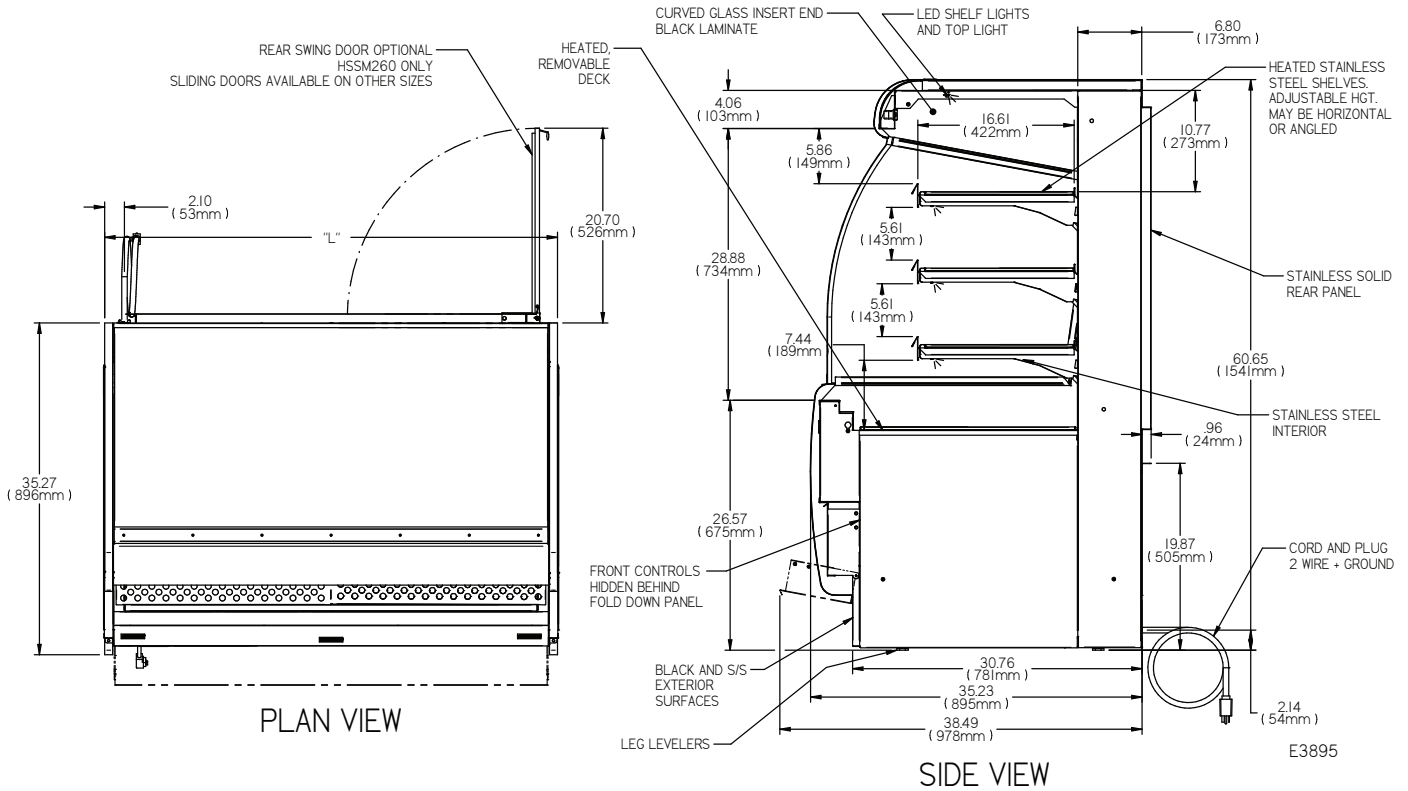

MODEL	DIMENSIONS				TOTAL CHICKEN BOAT CAPACITY	SHIPPING WT		VOLTAGE/AMPS/PH	STANDARD NEMA PLUG	KW RATING
	L	D	H	UNITS		LBS	KILO		CONFIG (SC)	
HSSM260	24.1	35.2	60.6	in	15 Lengthwise	350	159	208-240 6.7/8A/1 PH	6-15P	1.4/1.9
	612	894	1539	mm	18 Sideways					
HSSM360	36.1	35.2	60.6	in	20 Lengthwise	400	181	208-240 10.4/12A/1PH	6-15P	2.16/2.9
	917	894	1539	mm	27 Sideways					
HSSM460	48.1	35.2	60.6	in	30 Lengthwise	550	250	208-240V 14.1/16.5A/1PH	6-20P	2.94/4
	1217	894	1539	mm	36 Sideways					

- Packaged food products placed in case must be pre-heated before placing in case.
- Due to continuing engineering improvements, specifications are subject to change without notice.



FEDERAL INDUSTRIES
 A Standex Company
 215 Federal Avenue, Belleville, Wisconsin 53508-9201

Phone: 800-356-4206
Fax: 608-424-3234
Email: Geninfo@Federalind.com
Website: Federalind.com