



Project \_\_\_\_\_  
 AIA # \_\_\_\_\_ SIS # \_\_\_\_\_  
 Item # \_\_\_\_\_ Quantity \_\_\_\_\_ C.S.I. Section 114000

## CLUC-72R

### Compact Undercounter Refrigerator Self-Contained Drawers

Compact Undercounter Refrigerator



### STANDARD PRODUCT FEATURES

- High Quality Stainless Steel Construction
- Anodized Aluminum Interior
- LED Display Control for Accuracy and Easy Monitoring
- Capillary Tube Metering Device
- Forced Air Refrigeration System Maintains Cabinet Temperature of 32°F to 41°F
- Six (6) Fully Removable Drawers
- Each Drawer Accommodates One (1) 1/2 Size Pan and One (1) 1/3 Size Pan
- Set of Six (6) 4" High Casters with Locks Standard
- Gasket-Protecting Retainer
- Self-Contained Rear-Mounted Refrigeration System
- High-Density, Non-CFC Foamed In Place Polyurethane Insulation
- Easy to Grip Drawer Handle(s)
- 3 Year Parts & Labor Warranty, Additional 2 Years on Compressor Parts



This unit is listed to the applicable UL, CSA and NSF Standards by an approved NRTL. Consult the factory or unit's data plate for approval information.

### ACCESSORIES & OPTIONS (Available at Extra Cost)

- + Set of Four (4) 6" High Legs
- + Set of Six (6) 6" High Casters
- + Set of Four (4) 2-3/4" High Casters

### AVAILABLE CONFIGURATIONS

#### DRAWER MODELS

CLUC-72R-DW Six (6) Drawers

Model	Drawers	Dimensions L x D x H (in.)	Voltage	Amps	NEMA	Cu. Ft.
CLUC-72R-DW	6	72.25 x 31.5 x 30	115/60/1	3.6	5 - 15P	18.80

\*Note: 30 in. height without casters

Approved by \_\_\_\_\_ Date \_\_\_\_\_ Approved by \_\_\_\_\_ Date \_\_\_\_\_

**MODEL - CLUC-72R-DW**

Drawer Models

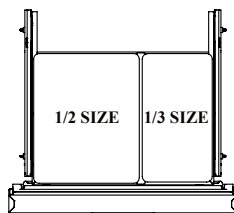
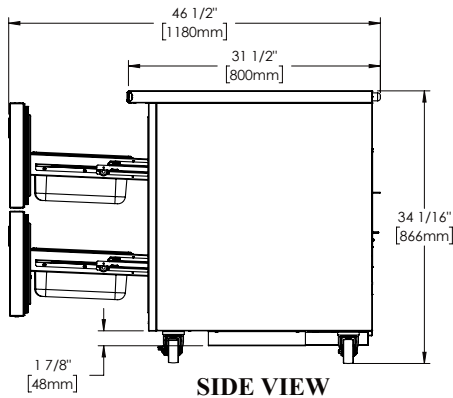
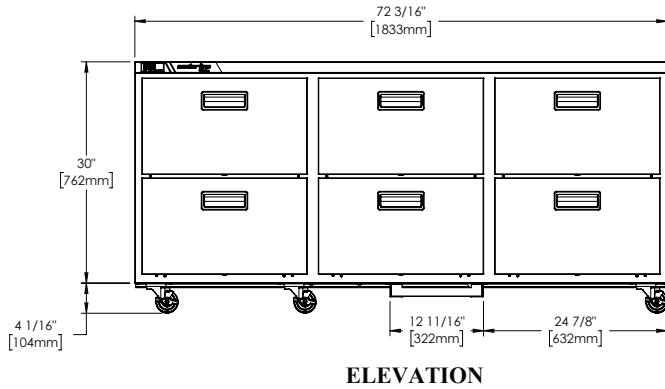

**SPECIFICATIONS**

**CONSTRUCTION, HARDWARE, INSULATION**

Cabinet exterior front, sides, and drawers are constructed of stainless steel. Cabinet interior is constructed of anodized aluminum. A set of four (4) 4" high casters are included. Drawers are equipped with a gasket protecting retainer. Both the cabinet and drawers are insulated with an average of 2-3/8" thick high density, non-CFC, foamed in place polyurethane insulation.

**REFRIGERATION SYSTEM**

A rear mounted, self-contained, balanced refrigeration system using environmentally friendly, non-flammable R-450A refrigerant is provided. It features an easy to clean rear facing condenser, capillary tube metering device, and air-cooled hermetic compressor. A 9' cord and plug is provided. Standard operating temperature is 32°F to 41°F. Energy efficient refrigeration system maintains safe product temperatures. Condenser is located in the back of the unit for easy maintenance and zero clearance.

**CONTROLLER**

The easy to use electronic digital control is supplied standard. It includes a 3-Digit LED display, and a Fahrenheit or Celsius temperature scale display capability.

**DRAWERS**

Drawer exterior, liner, and frame are constructed of stainless steel. Each drawer has foamed-in place recessed handle for easy grip. Heavy-duty drawers are removable without tools for easy cleaning. Each drawer accommodates one (1) 1/2 size food pan and one (1) 1/3 size food pan (sold separately).

**WARRANTY**

Both a 3 Year Parts & Labor Warranty and additional 2 Years on Compressor Parts Warranty are supplied standard.

MODELS	CLUC-72R-DW
<b>ELECTRICAL DATA</b>	
Voltage	115/60/1
Full Load Amperes	3.6
<b>REFRIGERATION DATA</b>	
Refrigerant	R-450A
Refrigerant Charge oz.	11.0 (312 gr)
BTU/HR   H.P <sup>1</sup>	1900   1/4
<b>SHIPPING DATA</b>	
Depth Crated in.	35 (88.9 cm)
Height Crated in.	37 (94 cm)
Length Crated in.	77 (195.6 cm)
Volume Crated cu. ft.	57.7 (1634 l)
Net Weight lbs.	310 (140.4 kg)
Gross Weight lbs.	344 (156 kg)

**NOTES:**

1. BTU/HR based on a 90°F ambient and 20°F evaporator

Equipped with one NEMA 5-15P Plug

