



Project _____
 AIA # _____ SIS # _____
 Item # _____ Quantity _____ C.S.I. Section 114000

CLBC4 Undercounter Blast Chiller Self-Contained



Undercounter Blast Chiller

STANDARD PRODUCT FEATURES

- High Performance Refrigeration System
- Quickly Chills Hot Food Product Directly from the Oven to under 41°F
- Stainless Steel Top, Front, Sides, Door & Interior
- Easy-to-Use Digital Control for Accuracy
- Adjustable Product Target Temps (40° to 32°F) or Cycle Times
- Two Chill Modes: Hard Chill & Soft Chill
- One (1) Food Probe
- Four (4) Epoxy Coated Wire Shelves
- Thermostatic Expansion Valve Metering Device
- Set of Four (4) 4" High Casters on Adjustable Channel System
- High-Density, Non-CFC Foamed in Place Polyurethane Insulation
- Easily Accessible Condenser Coil for Maintenance
- Left-Hand Refrigeration System Location
- Environmentally Friendly Non-Flammable Refrigerant
- 3 Year Parts & Labor Warranty, Additional 2 Years on Compressor Parts



This unit is listed to the applicable UL, CSA and NSF Standards by an approved NRTL. Consult the factory or unit's data plate for approval information.

ACCESSORIES & OPTIONS (Available at Extra Cost)

- + Set of Four (4) 6" High Casters
- + Set of Four (4) 6" High Legs
- + Stainless Steel Top with 4" Backsplash (refer to spec sheet TR36327 for model CLBC4-WT)

AVAILABLE CONFIGURATIONS

| MODELS | HINGING |
|---------|------------------------|
| CLBC4-L | Full Solid Door, Left |
| CLBC4-R | Full Solid Door, Right |

| Model | Doors | Shelves | Dimensions L x D x H (in.) | Voltage | Amps | NEMA | Ship Wt. (lbs.) | Net Capacity Cu. Ft. |
|-------|-------|---------|----------------------------|----------|------|---------|-----------------|----------------------|
| CLBC4 | 1 | 4 | 54.13 x 35.94 x 28* | 115/60/1 | 16 | 5 - 20P | 492 | 9.26 |

*Note: 28 in. height without 4 in. casters

As continued product improvement is a policy of Traulsen, specifications are subject to change without notice.

Approved by _____ Date _____ Approved by _____ Date _____

MODEL - CLBC4

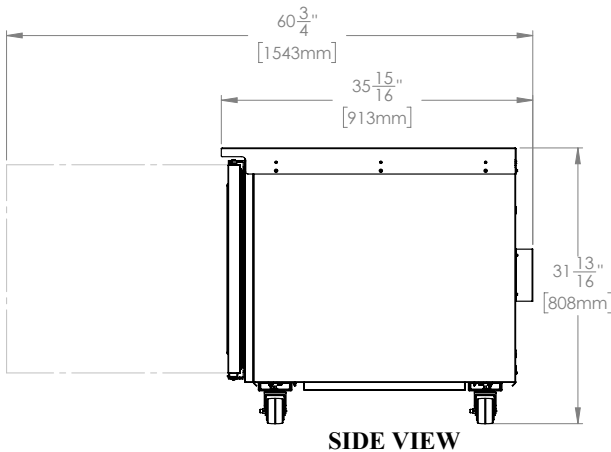
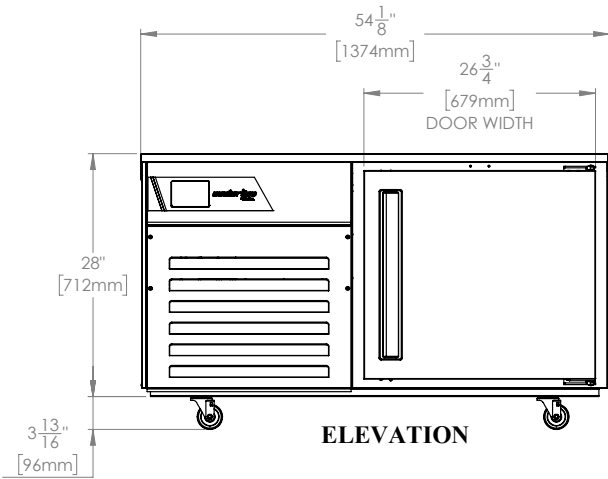
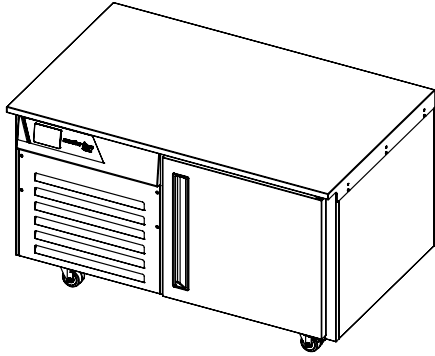

ESTIMATED PERFORMANCE CHART

| CLBC4 Product Load | Chill Time From 160°F to 40°F |
|--------------------|-------------------------------|
| 32 lbs. | 90 min. |
| 48 lbs. | 120 min. |

SPECIFICATIONS

CONSTRUCTION, HARDWARE, INSULATION

Cabinet top, front, interior, and door are constructed of heavy gauge stainless steel. The exterior cabinet back and bottom are constructed of heavy gauge galvanized steel. A set of four (4) 4" high casters are included. Door is equipped with a stay open feature at 120 degrees. Anti condensate heaters are located behind the door opening. Both the cabinet and door(s) are insulated with an average of 2" thick high density, non-CFC, foamed in place polyurethane insulation.

REFRIGERATION SYSTEM

A high-capacity, self-contained refrigeration system using environmentally friendly, non flammable R-448A refrigerant is coupled with an advanced air circulation system to rapidly chill hot food through the HACCP danger zone. The condenser coil is front facing for easy cleaning. Defrost occurs automatically. A 8' cord and plug is provided.

CONTROLLER

The easy to use 2.8 inch digital display is water resistant and has five (5) capacitive keys. Using the probe provided, it monitors cycle progress.

INTERIOR

Standard interior arrangements include four (4) epoxy coated wire shelves mounted on clips and pilasters.

WARRANTY

Both a 3 Year Parts & Labor Warranty and additional 2 Years on Compressor Parts Warranty are supplied standard.

| MODELS | CLBC4 |
|---------------------------|-------------------------------|
| DIMENSIONAL DATA | |
| Pan Capacity | (4) 18" x 26" (8) 12" x 20" |
| ELECTRICAL DATA | |
| Voltage | 115/60/1 |
| Feed Wires with Ground | 3 |
| Full Load Amperes | 16 |
| REFRIGERATION DATA | |
| Refrigerant | R-448A |
| Refrigerant Charge oz. | 24 oz (680.4 g) |
| BTU/HR' H.P. | 4445 1 |
| SHIPPING DATA | |
| Depth Crated in. | 42 (106.7 cm) |
| Height Crated in. | 41 (104.1 cm) |
| Length Crated in. | 66 (167.6 cm) |
| Volume Crated cu. ft. | 66 (1,869 l) |
| Net Weight lbs. | 362 (164.2 kg) |
| Gross Weight lbs. | 492 (223.1 kg) |

NOTES:

1. BTU/HR based on a 100°F ambient and 0°F evaporator

Equipped with one NEMA 5-20P Plug



CAD and/or Revit Files Available