

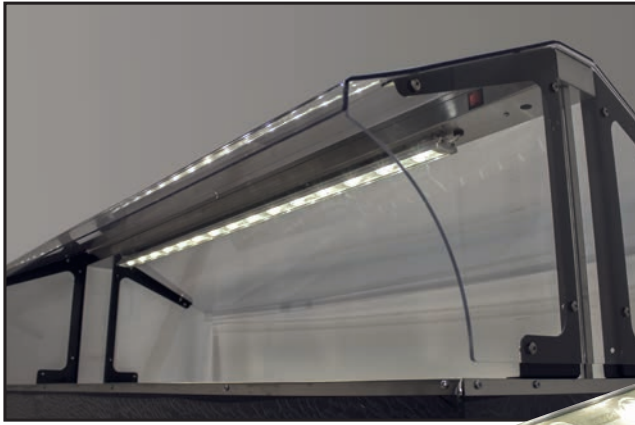

LED DISPLAY LIGHTING

For Everyday Buffets



Item #: _____ Qty #: _____
 Model #: _____
 Project #: _____

FEATURES:

Includes Class 2 Low Voltage Power Supply-120V-277V
 Available in White, Black & Natural Aluminum Finish

CONSTRUCTION:

High Impact resistant Mounting Clips

MATERIAL:

Aluminum Rail with Shatter-Proof Optics

NOTE: Shelves Require 6" clearance on both sides to fit above LED Lighting.
 5 amps per fixture regardless of length.

FACTORY INSTALLED ONLY • PRINT REQUIRED FOR PROPER LED LOCATION



MODEL #	Length (L)	Wt.
LED-B-2	24"	5 bs.
LED-B-3	36"	6 bs.
LED-B-4	48"	7 bs.
LED-B-5	60"	8 bs.
LED-B-6	72"	9 bs.

DETAILS and SPECIFICATIONS

TOL ± .500"

ALL DIMENSIONS ARE TYPICAL

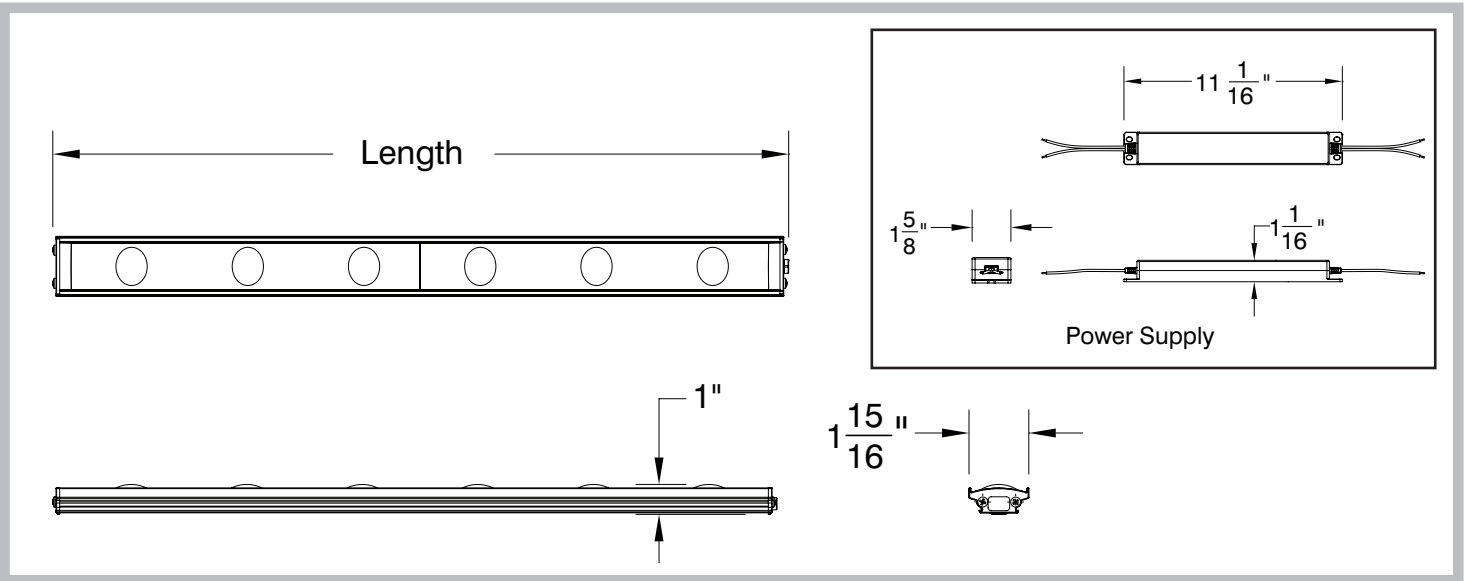

Customer Service Available To Assist You **1-800-645-3166** 8:30 am - 8:00 pm E.S.T.

For Orders & Customer Service:
 Email: customer@advancetabco.com or Fax: 631-242-6900

For Smart Fabrication™ Quotes:
 Email: smartfab@advancetabco.com or Fax: 631-586-2933