



# STAINLESS STEEL PORTABLE FOOD SHIELDS



PFS-36B Shown  
with Optional Side Panels

**Item #:** \_\_\_\_\_ **Qty #:** \_\_\_\_\_  
**Model #:** \_\_\_\_\_  
**Project #:** \_\_\_\_\_



FEATURING ADVANCE TABCO'S  
**REVOLUTIONARY CHAMBER LOCK™**  
 ROTATION SYSTEM

**Makes Rotating Food Shields Easier Than Ever**

**FEATURES:**

- 15" Front Panel Adjustable Sneeze Guard with Patent Pending Chamber Lock™ Technology
- Reversible Position Support Base
- Shipped K.D.

**CONSTRUCTION:**

- All TIG welded.
- 1/4" Thick Thermoplastic Polymer Sneeze Guard
- 1" Stainless Steel Posts
- 1-1/2" Wide x 14-1/2" Front to Back Black Support Base
- Requires Allen Wrench (Not Included)

Length	Model #	Approx. Wt.	Approx Cubes
36"	PFS-36B	12 lbs.	14
48"	PFS-48B	15 lbs.	18
60"	PFS-60B	18 lbs.	21
72"	PFS-72B	21 lbs.	24

CUSTOM COLORS AVAILABLE - CONSULT FACTORY

TOL ± .500" **DETAILS and SPECIFICATIONS** ALL DIMENSIONS ARE TYPICAL

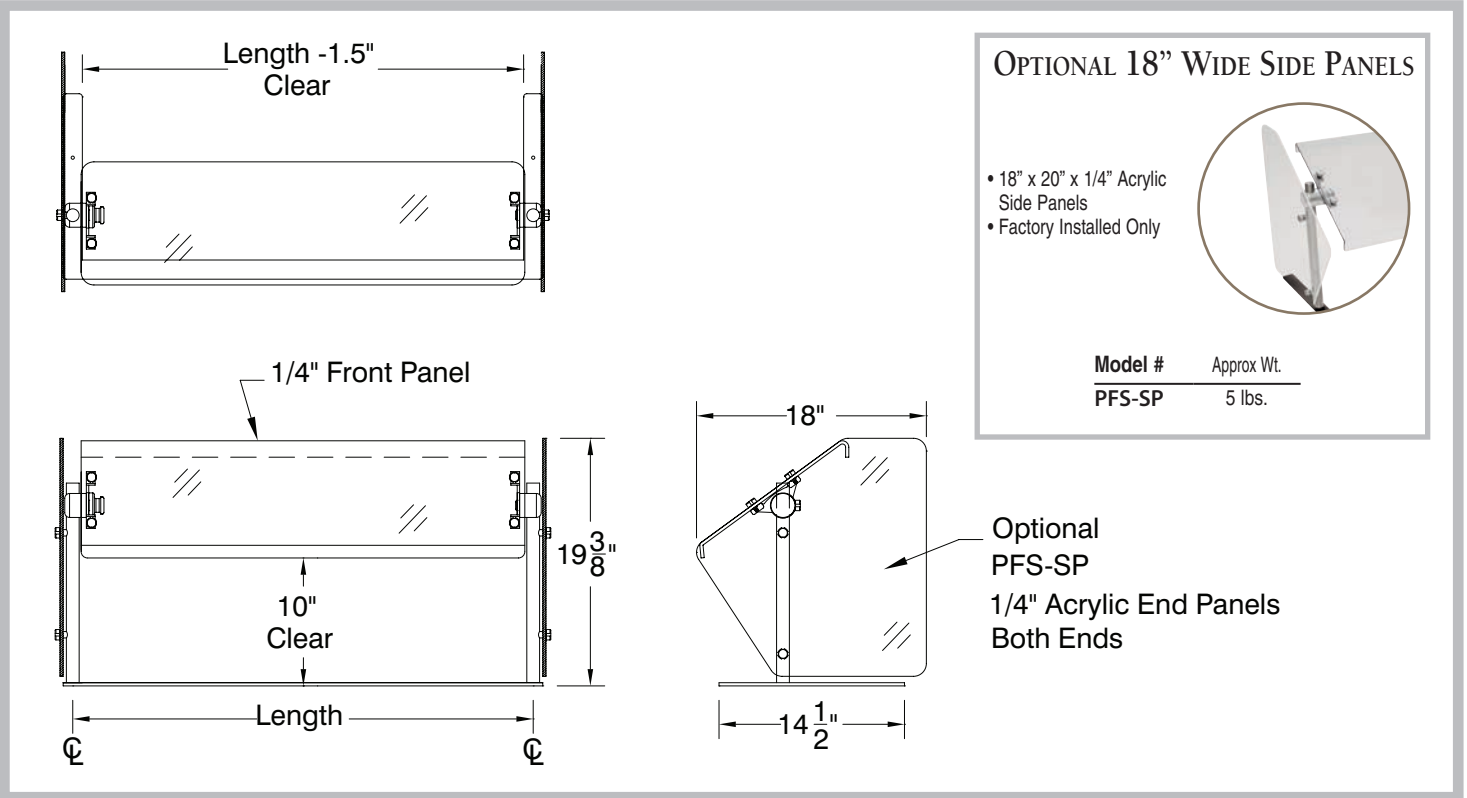

www.advancetabco.com

**Customer Service Available To Assist You 1-800-645-3166 8:30 am - 8:00 pm E.S.T.**

Email Orders To: customer@advancetabco.com. For Smart Fabrication™ Quotes, Email To: smartfab@advancetabco.com or Fax To: 631-586-2933

**NEW YORK**  
Fax: (631) 242-6900

**GEORGIA**  
Fax: (770) 775-5625

**TEXAS**  
Fax: (972) 932-4795

**NEVADA**  
Fax: (775) 972-1578