



STAINLESS STEEL GLASS RINSER

Item #: _____ Qty #: _____

Model #: _____

Project #: _____

FEATURES:

- Counter Top Mount
- Brushed Stainless Steel.
- 6" counter Mount.
- Mounts Easily In Underbar Equipment.
- Water Rinser & Glass Actuator By Pushing Down On Glass.
- Threaded Drain For 1/2" Drain Hose.

MATERIAL:

- 18 gauge stainless steel
- Stainless steel Water rinser and glass actuator construction.

MECHANICAL:

- 4-1/2" Glass Rinser Area
- Water Connection:** External -1/2" BSP (Standard Plumbing Connection)
- Drain Hose Connection:** 1/2" Flat Barb
- Drain:** Threaded Brass 3-1/2" x 5/8" x 18



Model #	Size W x L	Approx. Weight	Approx. Cu. Ft.
SU-16	6-3/8" x 6-3/8" x 3/4"	7 lbs.	1

DETAILS and SPECIFICATIONS

TOL Overall: ± .500" Interior: ± .250"

ALL DIMENSIONS ARE TYPICAL

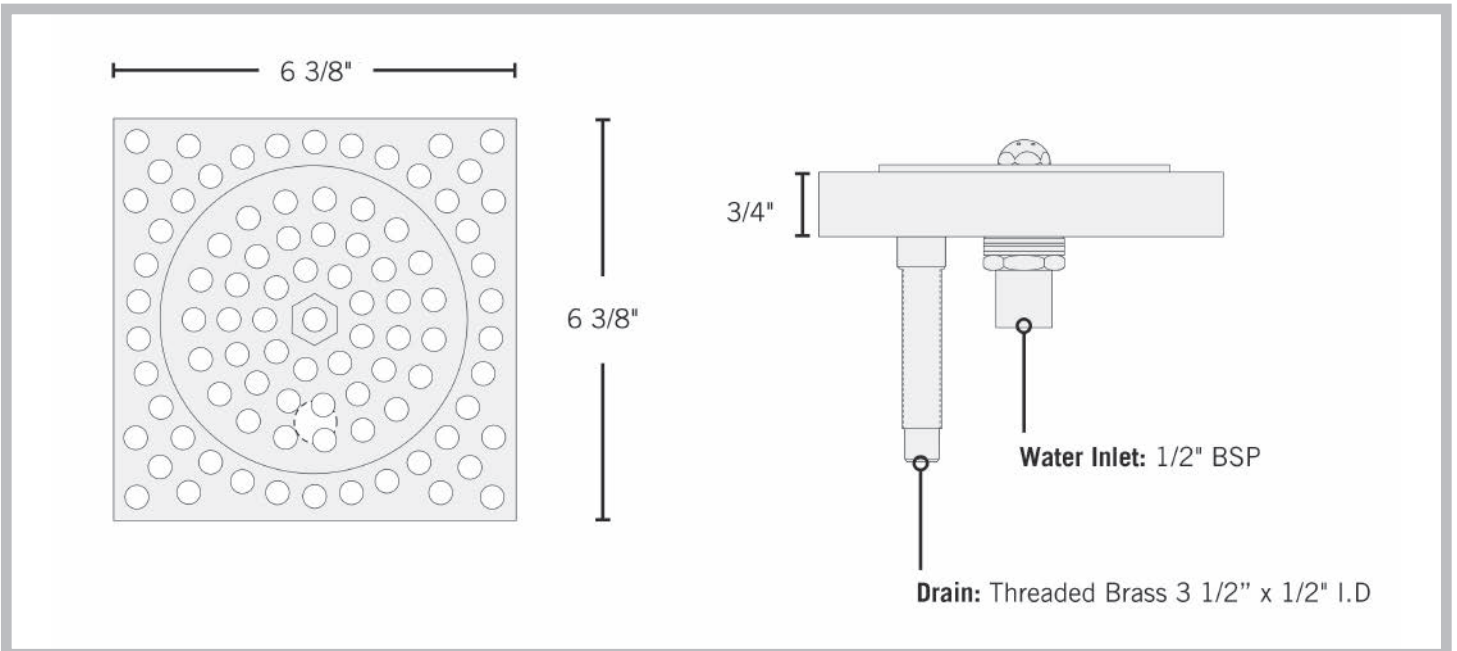

Customer Service Available To Assist You **1-800-645-3166** 8:30 am - 8:00 pm E.S.T.

For Orders & Customer Service:
Email: customer@advancetabco.com or Fax: 631-242-6900

For Smart Fabrication™ Quotes:
Email: smartfab@advancetabco.com or Fax: 631-586-2933