



SEALED WELL ELECTRIC TABLES WITH UNDERSHELF



SW-3E-240 Shown



Sealed Well with Drain

Item #: _____ Qty #: _____
 Model #: _____
 Project #: _____

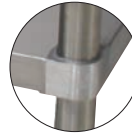

Featuring as Standard:
"THE PROVEN"
ORIGINAL ADVANCE TABCO
Adjustable Undershelf with Die Cast Leg Clamp

FEATURES:

- Stainless steel body, top and legs
- Stainless steel undershelf
- Fiberglass insulation between each compartment
- Drains with gate valves per well
- Stainless steel shelf with removable 3/8" thick poly cutting board - Ships K.D.

MATERIAL:

- TOP:** 20 gauge #302 stainless steel with die stamped pan openings. (11.875" x 20.062")
- BODY:** 22 gauge #430 stainless steel
- LEGS:** 1 5/8" diameter tubular stainless steel
1" adjustable plastic bullet feet
Stainless steel gussets
- UNDERSHELF:** 20 gauge, #430 stainless steel
- LINERS:** 20 Gauge stainless steel deep drawn with drain
- CUTTING BOARD:** White Thermoplastic
- CUTTING BOARD BRACKETS:** 16 gauge, #302 stainless steel

ELECTRICAL:

- 120V units yield 640 Watts
- 208V/240V dual voltage units yield 825 Watts at 208V and 1100 Watts at 240V
- 6' electrical cord with plug
- Infinite control knobs
- Indicator lights



Model #	Length	# of Wells	Volts	Amps	Watts	NEMA Plug	Wt.	Cu. Ft.
SW-2E-120	A = 31-13/16"	2	120	10.67	1280	5-20P	92 lbs.	28
SW-3E-120	B = 47-1/8"	3	120	16	1920	5-20P	135 lbs.	41.32
SW-4E-120	C = 62-7/16"	4	120	21.33	2560	L5-30P	230 lbs.	54.55
SW-2E-240	A = 31-13/16"	2	208/240	7.94/9.16	1650/2200	6-20P	92 lbs.	28
SW-3E-240	B = 47-1/8"	3	208/240	11.91/13.74	2475/3300	6-20P	135 lbs.	41.32
SW-4E-240	C = 62-7/16"	4	208/240	15.88/18.32	3300/4400	L6-30P	230 lbs.	54.55
SW-5E-240	D = 77-3/4"	5	208/240	19.85/22.90	4125/5500	L6-30P	270 lbs.	66.94

NOTE: Units are not designed to cook or heat frozen or refrigerated foods. Food placed in tables should already be hot, and the table will maintain the proper temperatures

NEMA PLUGS: Your plug will look like this...



NEMA 5-20P



NEMA 6-20P



NEMA L5-30P



NEMA L6-30P



Customer Service Available To Assist You 1-800-645-3166 8:30 am - 8:00 pm E.S.T.

For Orders:

Email: customer@advancetabco.com or Fax To: 631-242-6900

For Smart Fabrication™ Quotes:

Email: smartfab@advancetabco.com or Fax To: 631-586-2933

DIMENSIONS and SPECIFICATIONS

TOL ± .125"

ALL DIMENSIONS ARE TYPICAL

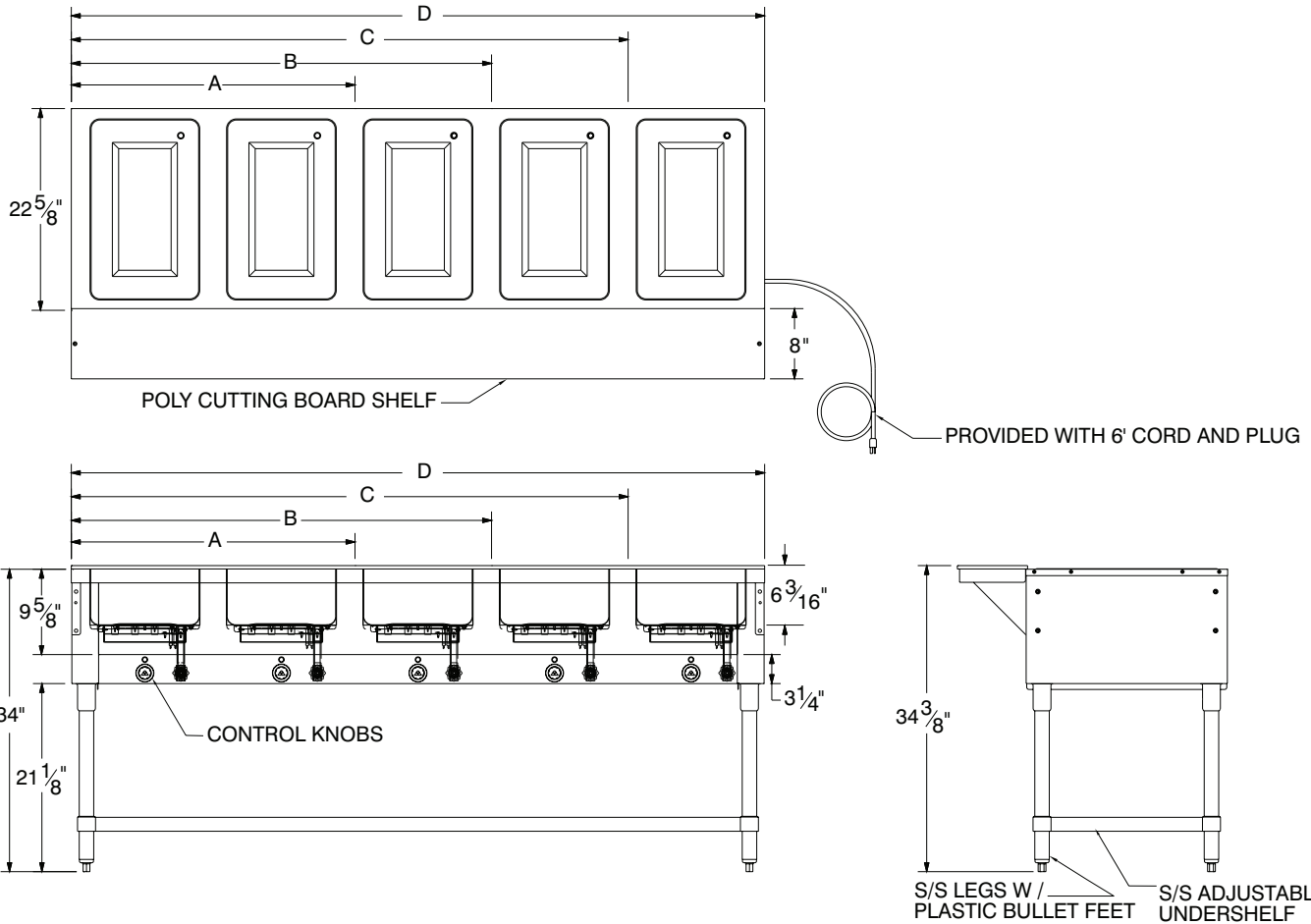

Food Table Shelving



Model	Length	Approx Wt.	Cu. Ft.
TBS-2	31-13/16"	34 lbs.	2
TBS-3	47-1/8"	42 lbs.	3
TBS-4	62-7/16"	47 lbs.	4
TBS-5	77-3/4"	55 lbs.	4

Acrylic Side Panels for Buffet Shelf
Add side panels to meet additional NSF requirements (2 panels per side)
TBP-1 One Side
TBP-2 Two Sides
Field Installation Available



Model	Length	Approx Wt.	Cu. Ft.
TSS-2	31-13/16"	18 lbs.	2
TSS-3	47-1/8"	23 lbs.	3
TSS-4	62-7/16"	30 lbs.	4
TSS-5	77-3/4"	35 lbs.	4

Acrylic Side Panel for Serving Shelf
Add side panels to meet additional NSF requirements (1 panel per side)
TSP-1 One Side
TSP-2 Two Sides
Field Installation Available

Food Table Accessories

Visit our website for additional Food Table Accessories

SU-25S Add Casters to Food Units with Undershelf (Includes 4 -5" Swivel Casters, 2 w/ Brakes & Legs That Maintain Height)

SU-25 Add Casters to Food Units with Undershelf (For Units Built Before Oct. 2015. Includes 4 -5" Swivel Casters, 2 w/ Brakes.)

TCB-OMIT Remove Poly Cutting Board

SU-45A 12" x 1" Adapter Bar

SU-45B 20" x 3" Adapter Bar



-T Thermostatic Control (Per Well)

-M Manifold Drains (Per Well)

