



Sleek Shields™

SELF SERVICE FOOD SHIELDS

DOUBLE SIDED - SINGLE TIER

Protected by: Patent No. US 9,010,883 B2



GSGD-40-96 Series Shown

Advance Tabco's Revolutionary "Chamber Lock" System
Makes Rotating Food Shields Easier Than Ever

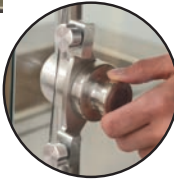

Item #: _____ Qty #: _____
 Model #: _____
 Project #: _____

FEATURES:

- 40" Wide Units
- Front glass locks in place at 15° intervals.
- Attractive, low profile design & Easy to clean.
- 1" Stainless Steel Posts.
- Chamber lock™ is mounted to post in a fixed position.
- Includes Two 15-3/8" High Side Panels.
- Heat-Tempered Glass on all 4 sides.
- 6 3/4" Standard front glass height.

TOP:

- NSGD Series:** Stainless Steel Shelf.
- GSGD Series:** Tempered Glass Top.

CONSTRUCTION:

- All TIG welded.
- Exposed stainless steel surfaces polished to a satin finish.

MATERIAL:

- NSGD Series:** 18 Ga., Type 430 Stainless Steel shelf.
- GSGD Series:** 3/8" Heat-Tempered Glass Top.
- 1/4" Thick Heat-Tempered Side Glass.
- 1" Posts - Stainless Steel
- Chamber Lock™ - Anodized Aluminum.
- Finish - Aluminum components manufactured with a standard Satin Clear Finish. Other colors available for Aluminum Components Only. Please consult factory for additional colors.

Length (L)	w/Stainless Steel shelf Model #	w/Glass Top Model #	Approx. Weight	Approx. Cu. Ft.
36"	NSGD-40-36	GSGD-40-36	119 lbs.	11
48"	NSGD-40-48	GSGD-40-48	132 lbs.	14
60"*	NSGD-40-60	GSGD-40-60	148 lbs.	18
72"†	NSGD-40-72	GSGD-40-72	173 lbs.	21
84"†	NSGD-40-84	GSGD-40-84	198 lbs.	24
96"†	NSGD-40-96	GSGD-40-96	227 lbs.	27
108"*†	NSGD-40-108	GSGD-40-108	251 lbs.	30
120"*†	NSGD-40-120	GSGD-40-120	278 lbs.	33
132"*†	NSGD-40-132	GSGD-40-132	309 lbs.	36
144"*††	NSGD-40-144	GSGD-40-144	340 lbs.	39

*3/8" Thick Heat-Tempered Glass Required For Front Glass

† Requires a single center post (Factory Print Required)

†† Requires two center posts (Factory Print Required)

Optional Accessories

(Compatible With All Advance Tabco Food Shields)



SG-1



SG-C



SG-S

SG-1 Surface Mounting Brackets for use when access below countertop is not available. Fits 1" Posts. 2" Dia.

SG-3 Modify Food Shield mounting for countertops exceeding 3/4" thick.

SG-C Upgrade Food Shield Leg to be cantilevered over installed equipment (Per Leg). Cannot replace End Posts/Brackets. Consult factory for special applications.

SG-S Sleek Shield™ horizontal swivel bracket. Used to connect food shields positioned at variable angles.

SG-AN Custom Color Anodizing for Sleek Shields™ for Aluminum Components.

SG-PC Powder Coating for Sleek Shields™ For Stainless Steel Components.

Standard Concealed Mounting Hardware

Requires access below counter for installation.

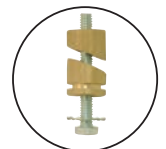
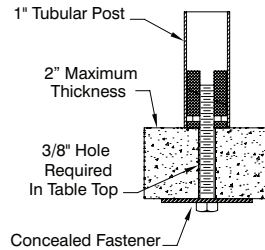

Brass Expander Included

Brass Expander Table Mounting Hardware Included.
For traditional undermount installation (1" tubing only)



Customer Service Available To Assist You 1-800-645-3166 8:30 am - 8:00 pm E.S.T.

For Orders & Customer Service:

Email: customer@advancetabco.com or Fax: 631-242-6900

For Smart Fabrication™ Quotes:

Email: smartfab@advancetabco.com or Fax: 631-586-2933

DETAILS and SPECIFICATIONS

TOL ± .500"

ALL DIMENSIONS ARE TYPICAL

NSGD-40 SERIES WITH STAINLESS STEEL SHELF

(NSGD-40-96 Shown with Required Additional Center Post)

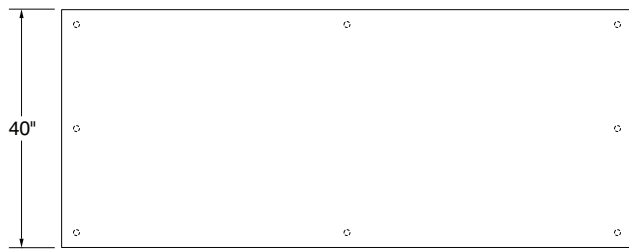

TOP VIEW

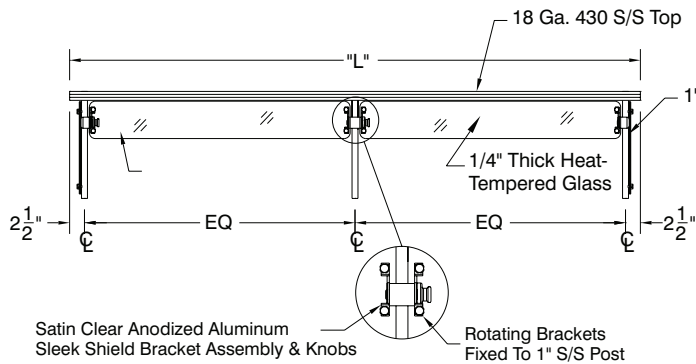

Standard Concealed Mounting Hardware

Requires access below counter for installation.

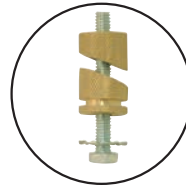

Brass Expander Table Mounting Hardware Included. For traditional undermount installation (1" tubing only)

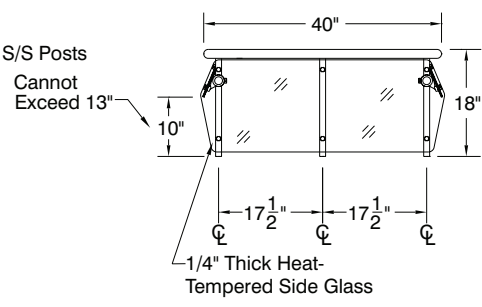
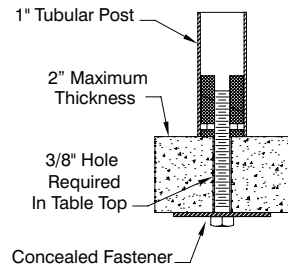

GSGD-40 SERIES WITH GLASS TOP

(GSGD-40-96 Shown with Required Additional Center Post)

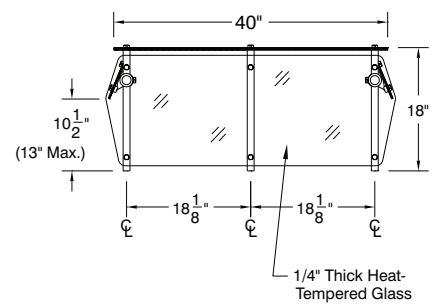
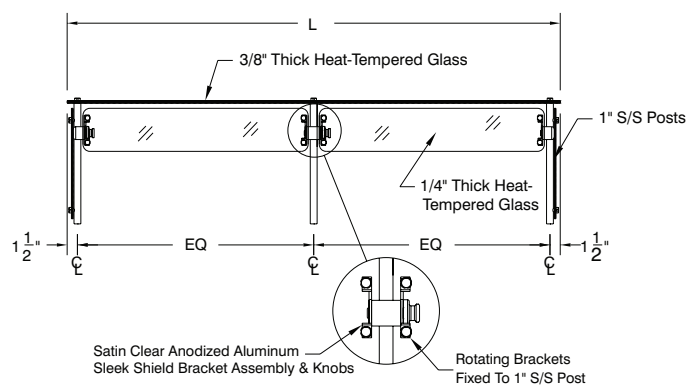
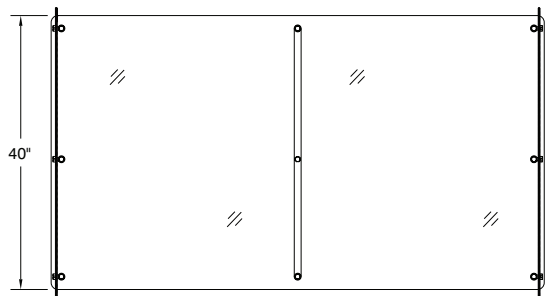

Maximum Front Glass Opening is 13" From Table to Bottom of Glass. Max. load for Top Glass is 100 lbs. even distributed weight
NOTE: Glass panels that exceed 66" will require a center support/posts.

