



BEVERAGE-AIR

Project: _____

AIA#

Item: _____

Location: _____

SIS#

Approved: _____

BB BACK BAR EQUIPMENT

BB72HC Glass Door Pass-Thru
Hydrocarbon Series

MODEL:

BB72HC-1-G-PT-B

BB72HC-1-G-PT-S

3 Year Parts/Labor Warranty
Additional 2 Year Compressor Warranty

CABINET CONSTRUCTION

- Black or stainless steel exterior
- Interior construction utilizes galvanized steel on walls and ceiling, heavy duty stainless steel floor
- Full electronic control
- Galvanized sub-top standard
- Two (2) epoxy coated shelves per section, standard
- Self-closing doors
- Stay-open feature & lock standard
- Magnetic door gaskets provide positive door sealing
- LED lighting
- Field reversible doors



BB72HC-1-G-PT-B

OPTIONS & ACCESSORIES

- 2" Stainless steel top
- 3"-6" casters or 6" black legs
- Wine model (40°-60° models)
- Wire shelf dividers
- Food rated models available
- Foot pedal door opener
- Solid or sliding glass doors

REFRIGERATION SYSTEM

- Refrigeration system uses R290 refrigerant to comply with all environmental concerns
- Balanced forced-air refrigeration system provides rapid chilling of product
- Automatic, non-electric evaporator
- Epoxy coated evaporator coil

BB72HC Back Bar Refrigerators: Pass-Thru Series



3779 Champion Blvd., Winston-Salem, NC 27105
1-888-845-9800 Fax: 1-336-245-6453
Beverage-Air.com sales@bevair.com



BEVERAGE-AIR

Bar Equipment-Back Bar Refrigerator Glass Door Pass-Thru

Model: BB72HC-1-G-PT-B, BB72HC-1-G-PT-S

MODEL	BB72HC-1-G-PT-B	BB72HC-1-G-PT-S
EXTERNAL DIMENSIONAL DATA		
Width Overall	72"	72"
Depth Overall with Handles	27 3/8"	27 3/8"
Height Overall	34"	34"
Number of Doors	3	3
Depth with Door Open 90°	63 3/4"	63 3/4"
Door Opening (in)	17 7/8" x 29 1/4"	17 7/8" x 29 1/4"
Shelf Area (sq. in)	334 19/64"	334 19/64"
INTERNAL DIMENSIONAL DATA		
NET Capacity (cubic ft.)	22.1	22.1
Internal Width Overall (in)	60 1/4"	60 1/4"
Internal Depth Overall (in)	19 3/8"	19 3/8"
Internal Height Overall (in)	28"	28"
Number of Shelves	6	6
Number of Kegs	3	3
ELECTRICAL DATA		
Full Load Amperes 115/60/1	3	3
REFRIGERATION DATA		
Horsepower	1/3	1/3
Capacity (BTU/Hr)*	1942	1942
WEIGHT DATA		
Gross Weight (Crated lbs)	425 lbs	420 lbs
Height - Crated	43"	43"
Width - Crated	75"	75"
Depth - Crated	29"	27"

Model Views

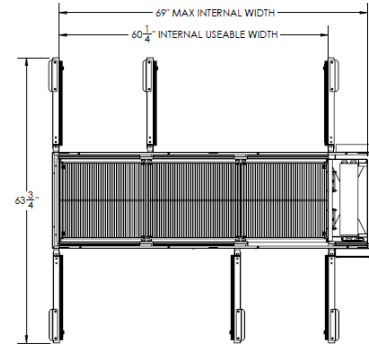

Plan View

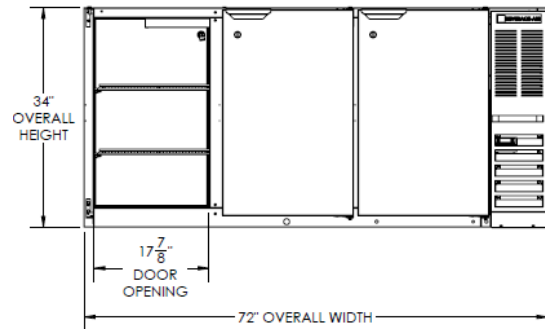

Elevation View

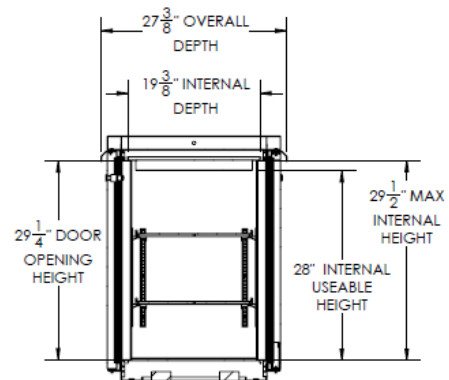

Side View

ELECTRICAL CONNECTION



115/60/1
NEMA-5-15P

Units pre-wired at
factory and include 8'
long cord and plug set.

