



# BEVERAGE-AIR

Project: \_\_\_\_\_

AIA#

Item: \_\_\_\_\_

Location: \_\_\_\_\_

SIS#

Approved: \_\_\_\_\_

## DD Draft Beer Equipment-Direct Draw Dispenser

DD36HC Solid Door

Hydrocarbon Series

**MODELS:**

**DD36HC-1-B**

**DD36HC-1-S**



**DD36HC-1-B**

**3 Year Parts/Labor Warranty**  
**Additional 2 Year Compressor Warranty**

### CABINET CONSTRUCTION

- Exterior is wear resistant vinyl on steel in black or stainless steel finish
- Top is made from heavy-duty stainless steel including drip tray
- Interior is galvanized steel on walls and ceiling, reinforced floor and doorsill are heavy duty stainless steel
- Full electronic control
- Drain tube located at bottom front of cooler or connection to floor drain
- 3" Insulated dispensing tower(s) with single draft arm
- Self-closing doors with locks
- Magnetic gaskets provide positive door seal
- Field reversible doors
- Compressor available on left or right, specify at time of unit order

### OPTIONS & ACCESSORIES

- Stainless steel interior available
- Turbo taps
- Wine models
- Wine taps
- Faucet locks
- Glass rinser
- 3"-6" casters or 6" black legs
- Foot pedal door opener
- 1-4 Tap tower
- 2, 3 & 4 way manifolds

### REFRIGERATION SYSTEM

- Refrigeration system uses R290 refrigerant to comply with all environmental concerns
- Models feature forced air refrigeration to keep beer in kegs ice cold for dispensing
- Automatic, non-electric evaporator
- Epoxy coated evaporator coil

**DD36HC Direct Draw Dispenser: Standard Models**



3779 Champion Blvd., Winston-Salem, NC 27105

1-888-845-9800 Fax: 1-336-245-6453

Beverage-Air.com sales@bevair.com



# BEVERAGE-AIR

## Bar Equipment-Direct Draw Dispenser Solid Door

Models: DD36HC-1-B, DD36HC-1-S

MODEL	DD36HC-1-B	DD36HC-1-S
<b>EXTERNAL DIMENSIONAL DATA</b>		
Width Overall	36"	36"
Depth Overall	24 1/4"	24 1/4"
Height Overall	36"	36"
Number of Doors	1	1
Depth with Door Open 90°	48 3/4"	48 3/4"
Door Opening (in)	23 7/8" x 29"	23 7/8" x 29"
<b>INTERNAL DIMENSIONAL DATA</b>		
NET Capacity (cubic ft.)	8.31	8.31
Internal Width Overall (in)	24 1/4"	24 1/4"
Internal Depth Overall (in)	18 5/8"	18 5/8"
Internal Height Overall (in)	29 1/2"	29 1/2"
Number of Kegs	1	1
<b>ELECTRICAL DATA</b>		
Full Load Amperes 115/60/1	3.2	3.2
<b>REFRIGERATION DATA</b>		
Horsepower	1/4	1/4
Capacity (BTU/Hr)*	1702	1702
<b>WEIGHT DATA</b>		
Gross Weight (Crated lbs)	250 lbs	242 lbs
Height - Crated	43"	44"
Width - Crated	39"	38"
Depth - Crated	26 1/2"	27"

### Model Views

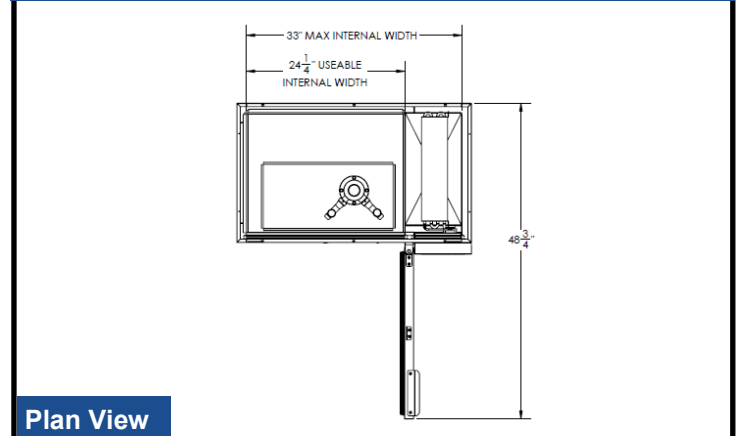

Plan View

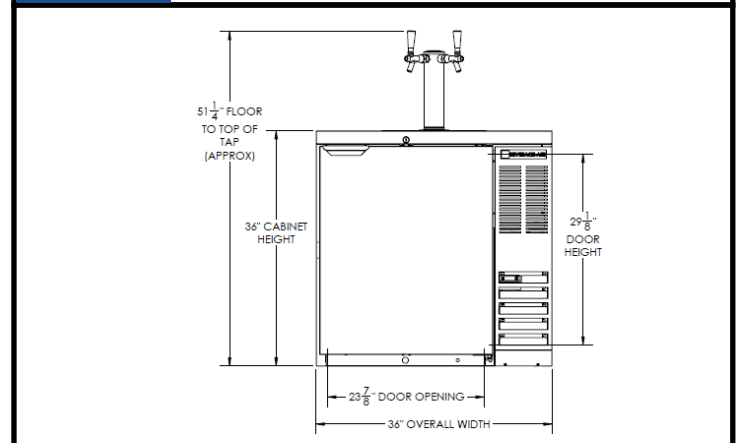

Elevation View

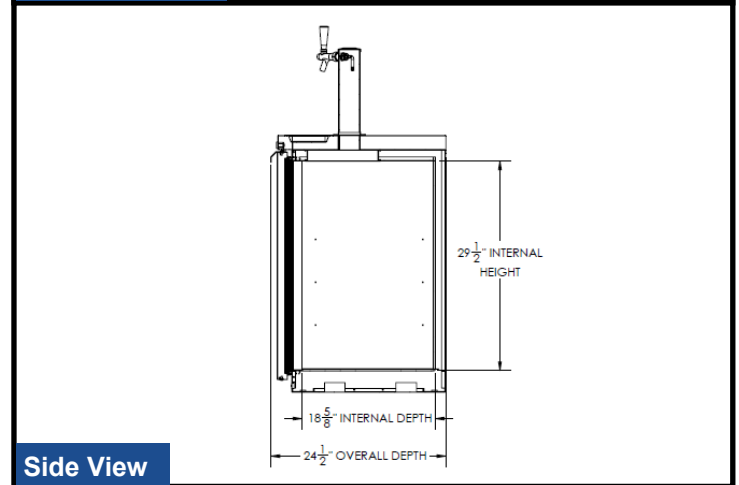

Side View

### ELECTRICAL CONNECTION



115/60/1  
NEMA-5-15P

Units pre-wired at  
factory and include 8'  
long cord and plug set.



an Ali Group Company



The Spirit of Excellence

3779 Champion Blvd., Winston-Salem, NC 27105  
1-888-845-9800 Fax: 1-336-245-6453