



# BEVERAGE-AIR

Project: _____	AIA# _____
Item: _____	
Location: _____	SIS# _____
Approved: _____	

## BOTTOM MOUNT REACH-IN FREEZER

FB72HC Solid Door Reach-in Freezer  
Hydrocarbon Series

**MODEL:**  
**FB72HC-5S**

FB72HC Bottom Mount Models: Vista Series



**FB72HC-5S**

**3 Year Parts/Labor Warranty**  
**Additional 2 Year Compressor Warranty**

### CABINET CONSTRUCTION

- Stainless steel front and door, gray painted sides
- Gray painted aluminum interior
- Full electronic control
- LED lighting standard
- Anti-microbial door handle
- Door lock (solid doors only)
- Self-closing door with 120° Stay-open feature, on spring-loaded hinges
- One -piece grille allow easy removal/installation for preventative maintenance
- Nine (9) heavy duty epoxy coated wire shelves standard
- 6" Caster standard with (2) brakes
- Maintains product temperatures of 0° F and below

### OPTIONS & ACCESSORIES

- Stainless steel universal tray slide pair, 1 tray slide set for (1) 18" x 26" or (2) 14" x 18" pans (AC)
- Epoxy shelves
- Shelf clips
- 3" caster or 6" legs
- Remote option

### REFRIGERATION SYSTEM

- Refrigeration system uses R290 refrigerant to comply with all environmental concerns
- Automatic, electric defrost
- Epoxy coated evaporator coil



3779 Champion Blvd., Winston-Salem, NC 27105  
1-888-845-9800 Fax: 1-336-245-6453  
Beverage-Air.com sales@bevair.com



# BEVERAGE-AIR

MODEL	FB72HC-5S
<b>EXTERNAL DIMENSIONAL DATA</b>	
Width Overall	75"
Depth Overall with Handle	33 3/4"
Height Overall with 6" casters	84 1/4"
Number of Doors	3
Depth with Door Open 90°	55 1/8"
Door Opening (in)	21 5/8" x 52 5/8" (3)
<b>INTERNAL DIMENSIONAL DATA</b>	
NET Capacity (cubic ft.)	68.5
Internal Width Overall (in)	72"
Internal Depth Overall (in)	25 7/8"
Internal Height Overall (in)	61 5/8"
Internal Height Useable (in)	53"
Number of Shelves	9
<b>ELECTRICAL DATA</b>	
Full Load Amperes 208-230/115	14.0
<b>REFRIGERATION DATA</b>	
Horsepower	(2) 3/4
Capacity (BTU/Hr)*	4624
<b>WEIGHT DATA</b>	
Gross Weight (Crated lbs)	725 lbs
Height - Crated	84"
Width - Crated	77 1/4"
Depth - Crated	36"

## Vista Series Bottom Mount Reach-in Freezer Model: FB72HC-5S

### Model Views

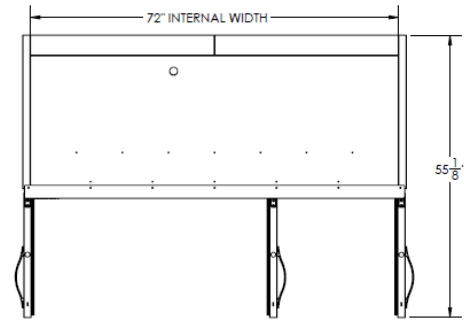

### Plan View

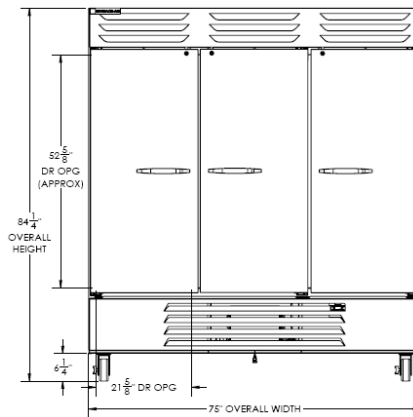

### Elevation View

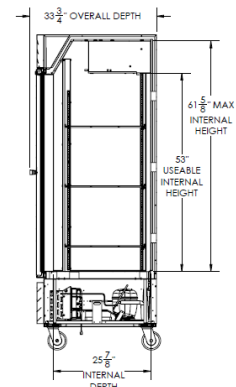

### Side View



### ELECTRICAL CONNECTION



125/250  
NEMA-L14-20P

Units pre-wired at factory and include 8' long cord and plug set.



an Ali Group Company



The Spirit of Excellence

3779 Champion Blvd., Winston-Salem, NC 27105  
1-888-845-9800 Fax: 1-336-245-6453  
Beverage-Air.com sales@bevair.com