



Project: _____	AIA#
Item: _____	
Location: _____	SIS#
Approved: _____	

HBF BOTTOM MOUNT REACH-IN FREEZERS

HBF44HC Solid Door Bottom Mount Freezer
Hydrocarbon Series

MODEL:
HBF44HC-1



HBF44HC-1

3 Year Parts/Labor Warranty
Additional 2 Year Compressor Warranty

CABINET CONSTRUCTION

- Stainless steel front, side, and grille (galvanized back & bottom)
- Stainless steel interior
- Full electronic control with one-touch defrost
- Expansion valve technology
- One -piece grille allow easy removal/installation for preventative maintenance
- Door locks (solid doors only)
- Self closing doors with 120° stay open feature
- Spring-loaded style hinges
- Plug-in magnetic door gaskets
- Anti-microbial door handles
- Six (6) heavy duty epoxy coated wire shelves
- LED lighting standard
- 6" Casters standard with two (2) brakes
- Maintains product temperatures of 0° F and below

OPTIONS & ACCESSORIES

- Stainless steel universal tray slide pair, 1 tray slide set for (1) 18" x 26" or (2) 14" x 18" pans (AC)
- 3" caster or 6" legs
- Epoxy shelves
- Shelf clips
- Remote option

REFRIGERATION SYSTEM

- Refrigeration system uses R290 refrigerant to comply with all environmental concerns
- Automatic, electric defrost
- Epoxy coated evaporator coil

HBF44HC Bottom Mount Models: Horizon Series



3779 Champion Blvd., Winston-Salem, NC 27105
1-888-845-9800 Fax: 1-336-245-6453
Beverage-Air.com sales@bevair.com



BEVERAGE-AIR

MODEL	HBF44HC-1
EXTERNAL DIMENSIONAL DATA	
Width Overall	47"
Depth Overall with Handle	33 3/4"
Height Overall with 6" Casters	84 1/4"
Number of Doors	2
Depth with Door Open 90°	53 5/8"
Door Opening (in)	(2) 20 1/8" x 52 5/8"
INTERNAL DIMENSIONAL DATA	
NET Capacity (cubic ft.)	44
Internal Width Overall (in)	44"
Internal Depth Overall (in)	26"
Internal Height Overall (in)	61 5/8"
Internal Height Useable (in)	53"
Number of Shelves	6
ELECTRICAL DATA	
Full Load Amperes 115/60/1	11
REFRIGERATION DATA	
Horsepower	3/4
Capacity (BTU/Hr)*	2312
WEIGHT DATA	
Gross Weight (Crated lbs)	562 lbs
Height - Crated	85"
Width - Crated	49"
Depth - Crated	36"

Bottom Mount Reach-ins Freezer Model: HBF44HC-1

Model Views

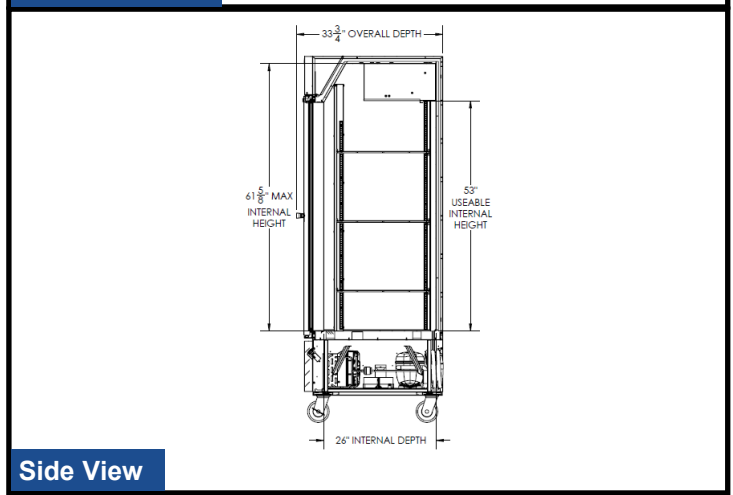
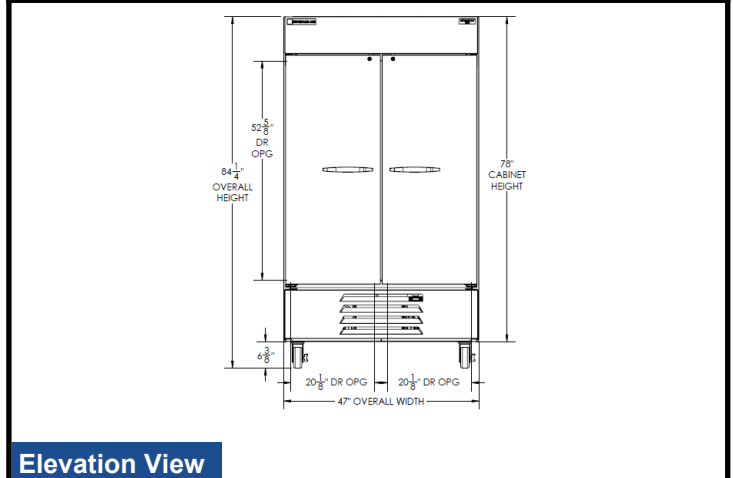
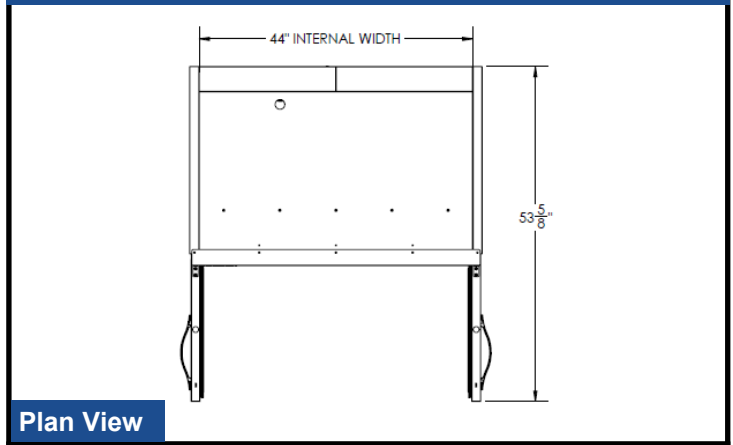

ELECTRICAL CONNECTION



115/60/1
NEMA-5-15P

Units pre-wired at factory and include 8' long cord and plug set.



an Ali Group Company



The Spirit of Excellence

3779 Champion Blvd., Winston-Salem, NC 27105
1-888-845-9800 Fax: 1-336-245-6453
Beverage-Air.com sales@bevair.com