



BEVERAGE-AIR

Project: _____

AIA#

Item: _____

Location: _____

SIS#

Approved: _____

FOOD PREPERATION TABLES

SPE36HC Elite Series Sandwich Prep

Hydrocarbon Series

MODELS:

SPE36HC-08



SPE36HC-08

**3 Year Parts/Labor Warranty
Additional 2 Year Compressor Warranty**

CABINET CONSTRUCTION

- Stainless steel front, sides, top, door(s), and grille (*galvanized back & bottom*)
- Interior liner is made of corrosion resistant aluminum
- Removable hoods and insulated lid assemblies are made of matching stainless steel
- Self-closing doors with 120° Stay-open feature, on cartridge style hinges
- Easy door removal for service and cleaning
- Field-reversible doors with snap-in door gaskets
- Painted aluminum door handle(s)
- 6" Casters, 2 with brakes standard
- 10" Wide cutting board constructed of white polyethylene plastic
- Cutting board removable for cleaning
- Two epoxy-coated steel wire shelves per section standard
- Pans furnished are 4" deep constructed of polycarbonate plastic

OPTIONS & ACCESSORIES

- Stainless steel interior option
- Stainless steel back
- Remote options
- Overshelves (single or double)
- Drawers or combination models
- Crumb catcher
- Modified pan openings
- Solid door with lock(s)
- 6" Legs
- 3" Casters
- Low profile casters
- Richlite cutting board
- Night cover

REFRIGERATION SYSTEM

- Refrigeration system uses R290 refrigerant to comply with all environmental concerns
- Recirculated, forced air from evaporator is moved under pans, which are recessed 2" from top of cabinet
- Automatic, non-electric evaporator
- System is serviceable from rear
- Epoxy coated evaporator coil

SPE36HC Elite Series Sandwich Prep: Standard Top Series



3779 Champion Blvd., Winston-Salem, NC 27105

1-888-845-9800 Fax: 1-336-245-6453

Beverage-Air.com sales@bevair.com



BEVERAGE-AIR

MODEL	SPE36HC-08
EXTERNAL DIMENSIONAL DATA	
Width Overall	36"
Depth Overall with Handle & Bumper	32"
Height Overall with 6" casters	45"
Number of Doors	2
Depth with Door Open 90 ° Extended	46 1/4"
Solid Door Opening (inches)	13 3/4" x 21 7/8"
Depth, Cutting Board	10"
Shelf Area (sq. in.)	Upper 215 3/4" Lower 245 33/64"
INTERNAL DIMENSIONAL DATA	
NET Capacity (cubic ft.)	7.3
Internal Width Overall (in)	32"
Internal Depth Overall (in)	15 3/8"
Internal Height Overall (in)	22"
Number of Shelves	4
Number of Pans	(8) 1/6 size
ELECTRICAL DATA	
Full Load Amperes 115/60/1	2.0
REFRIGERATION DATA	
Horsepower	1/6
Capacity (BTU/Hr)*	1140
WEIGHT DATA	
Gross Weight (Crated lbs)	250 lbs
Height - Crated	43"
Width - Crated	38"
Depth - Crated	33"

Food Preparation Table - Standard Top

Models: SPE36HC-08

Model Views

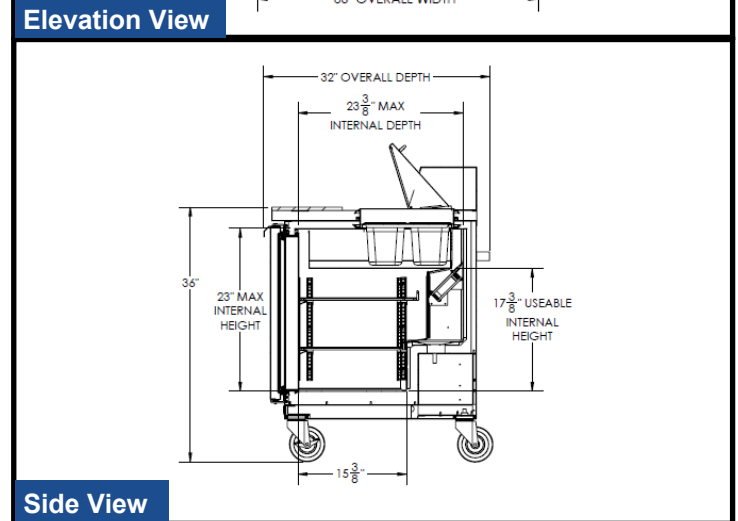
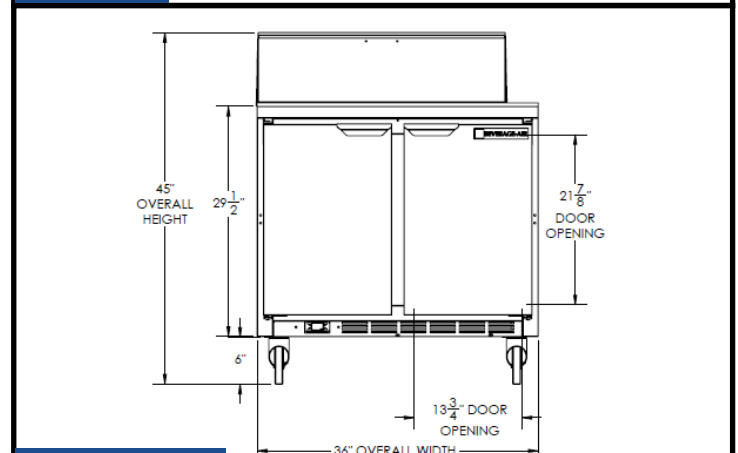
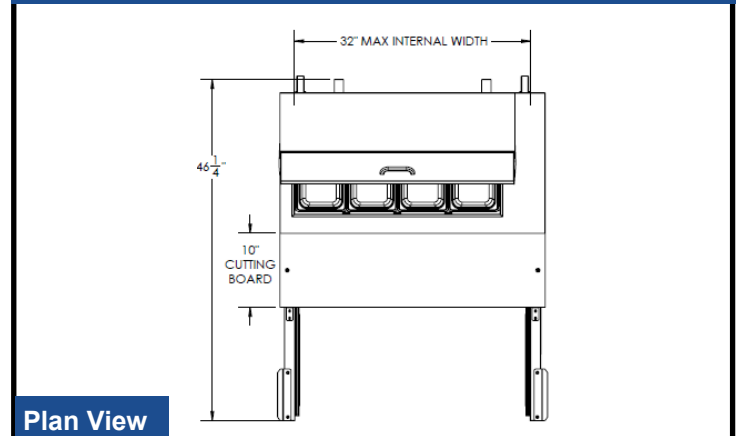

ELECTRICAL CONNECTION



115/60/1
NEMA-5-15P

Units pre-wired at factory and include 8' long cord and plug set.



an Ali Group Company



The Spirit of Excellence

3779 Champion Blvd., Winston-Salem, NC 27105
1-888-845-9800 Fax: 1-336-245-6453