



BEVERAGE-AIR

Project: _____

AIA#

Item: _____

Location: _____

SIS#

Approved: _____

FOOD PREPERATION TABLES

SPE72HC Elite Series Sandwich Prep
Hydrocarbon Series

MODELS:
SPE72HC-24M

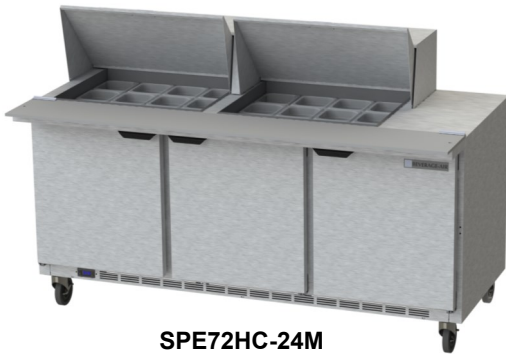

SPE72HC-24M

3 Year Parts/Labor Warranty
Additional 2 Year Compressor Warranty

CABINET CONSTRUCTION

- Stainless steel front, sides, top, door(s), and grille (galvanized back & bottom)
- Interior liner is made of corrosion resistant aluminum
- Full electronic control
- Removable hoods and insulated lid assemblies are made of matching stainless steel
- Self-closing doors with 120° Stay-open feature, on cartridge style hinges
- Field-reversible doors with snap-in door gaskets
- Painted aluminum door handle(s)
- 6" Casters, 2 with brakes standard
- 10" Wide cutting board constructed of white polyethylene plastic
- Cutting board removable for cleaning
- Two (2) epoxy-coated steel wire shelves per section standard
- Twenty-Four (24) 4" deep pans constructed of polycarbonate plastic

OPTIONS & ACCESSORIES

- Stainless steel interior option
- Stainless steel back
- Remote options
- Overshelves (single or double)
- Drawers or combination models
- Crumb catcher
- Modified pan openings
- Solid door with lock(s)
- 6" Legs
- 3" Casters
- Low profile casters
- Richlite cutting board
- Night cover

REFRIGERATION SYSTEM

- Refrigeration system uses R290 refrigerant to comply with all environmental concerns
- Airflow assures that product in open containers is kept below 41°F and above freezing
- Recirculated, forced air from evaporator is moved under pans, which are recessed 2" from top of cabinet
- Automatic, non-electric evaporator
- System is serviceable from rear
- Epoxy coated evaporator coil

SPE72HC Elite Series Sandwich Prep: Mega Top Series



3779 Champion Blvd., Winston-Salem, NC 27105
1-888-845-9800 Fax: 1-336-245-6453
Beverage-Air.com sales@bevair.com



BEVERAGE-AIR

MODEL	SPE72HC-24M
EXTERNAL DIMENSIONAL DATA	
Width Overall	72"
Depth Overall with Cutting Board & Bumper	38 3/8"
Height Overall with 6" Casters	49"
Number of Doors	3
Depth with Door Open 90 °	52 1/4"
Solid Door Opening (in)	19 1/2" x 21 5/8"
Depth, Cutting Board	10"
Shelf Area (sq. in)	(L/R) Upper 344 1/2" Lower 367 1/8" (CTR) Upper 302 3/4" Lower 302 3/4"
INTERNAL DIMENSIONAL DATA	
NET Capacity (cubic ft.)	14.6
Internal Width Overall (in)	68"
Internal Depth Overall (in)	15 3/8"
Internal Height Overall (in)	17 3/4"
Number of Shelves	6
Number of Pans	(24) 1/6 size
ELECTRICAL DATA	
Full Load Amperes 115/60/1	3
REFRIGERATION DATA	
Horsepower	1/4
Capacity (BTU/Hr)*	1549
WEIGHT DATA	
Gross Weight (Crated lbs)	404 lbs
Height - Crated	48"
Width - Crated	74"
Depth - Crated	38"

Food Preparation Table - Mega Top

Models: SPE72HC-24M

Model Views

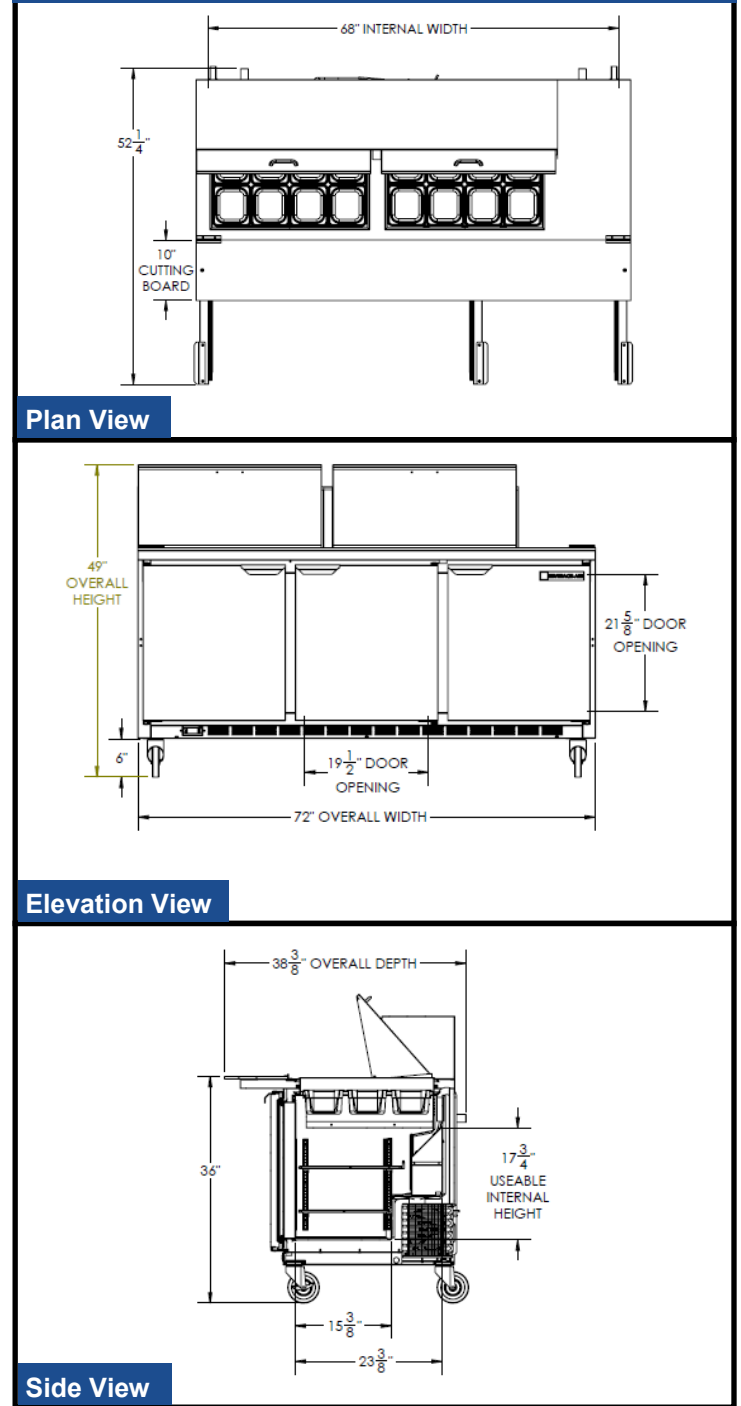

ELECTRICAL CONNECTION



115/60/1
NEMA-5-15P

Units pre-wired at factory and include 8' long cord and plug set.



an Ali Group Company



3779 Champion Blvd., Winston-Salem, NC 27105
1-888-845-9800 Fax: 1-336-245-6453