



# BEVERAGE-AIR

Project: _____	AIA#
Item: _____	SIS#
Location: _____	
Approved: _____	

## FOOD PREPERATION TABLES

SPED60HC Elite Series Sandwich Prep  
Hydrocarbon Series

**MODELS:**  
SPED60HC-18M-2



SPED60HC-18M-2

**3 Year Parts/Labor Warranty**  
**Additional 2 Year Compressor Warranty**

### CABINET CONSTRUCTION

- Stainless steel front, sides, top, door(s), drawer(s), and grille (galvanized steel back & bottom)
- Interior liner is made of corrosion resistant aluminum
- Removable hoods & and insulated lid assemblies are made of matching stainless steel
- Self-closing doors on cartridge style hinges, with 120° stay open feature
- Easy door removal for service and cleaning
- Field-reversible doors with snap-in door gaskets
- Painted aluminum door and drawer handle(s)
- 6" Casters, 2 with brakes standard
- Two epoxy-coated steel wire shelves standard
- 10" Wide cutting board constructed of white polyethylene plastic
- Cutting board removable for cleaning
- Pans furnished are 4" deep constructed of polycarbonate plastic
- Stainless steel drawer frames supported on telescoping drawer slides
- Drawer slides include locking mechanism that prevents drawers from being inadvertently pulled off cabinet
- Top and bottom drawers accommodate 6" deep pans

### OPTIONS & ACCESSORIES

- Stainless steel back options
- Stainless steel interior options
- Combination models available
- Overshelves (single or double)
- Crumb catcher
- Modified pan openings
- 6" Legs
- 3" Casters
- Low profile caters
- Richlite cutting board
- Night cover
- Remote options

### REFRIGERATION SYSTEM

- Refrigeration system uses R290 refrigerant to comply with all environmental concerns
- Recirculated, forced air from evaporator is moved under pans, which are recessed 2" from top of cabinet
- Automatic, non-electric evaporator
- System is serviceable from rear
- Epoxy coated evaporator coil

SPED60HC Elite Series Sandwich Prep: Mega Top Series



3779 Champion Blvd., Winston-Salem, NC 27105  
1-888-845-9800 Fax: 1-336-245-6453  
Beverage-Air.com sales@bevair.com



# BEVERAGE-AIR

MODEL	SPED60HC-18M-2
<b>EXTERNAL DIMENSIONAL DATA</b>	
Width Overall	60"
Depth Overall	38 3/8"
Height Overall with 6" Casters	49"
Number of Doors	1
Depth with Door Open 90°	55 1/4"
Door Opening (in)	22 5/8" x 21 x 21 5/8"
Shelf Area	Upper 439 21/64 Lower 386 1/8
Number of Drawers	2
Depth with Top Drawers Open Extended	47 3/4"
Drawer Opening (in)	Upper 22 5/8" x 11 1/8" Lower 22 5/8" x 7 1/2"
Depth, Cutting Board	10"
<b>INTERNAL DIMENSIONAL DATA</b>	
NET Capacity (cubic ft.)	12.2
Internal Width Overall (in)	56"
Internal Depth Overall (in)	15 3/8"
Internal Height Overall (in)	23"
Number of Shelves	2
Number of Pans	(18) 1/6 Size
<b>ELECTRICAL DATA</b>	
Full Load Amperes 115/60/1	3.0
<b>REFRIGERATION DATA</b>	
Horsepower	1/4
Capacity (BTU/Hr)*	1549
<b>WEIGHT DATA</b>	
Gross Weight (Crated lbs)	406 lbs
Height - Crated	48"
Width - Crated	62"
Depth - Crated	38"

## Food Preparation Table — Mega Top

Models: SPED60HC-18M-2

### Model Views

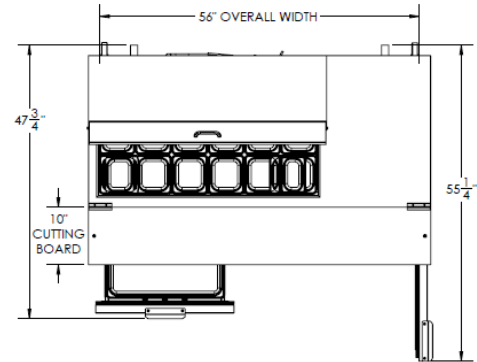

### Plan View

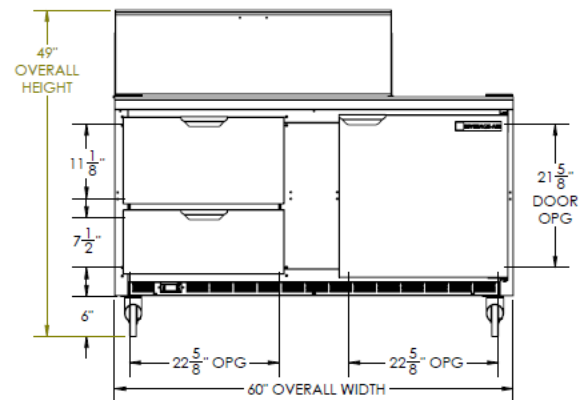

### Elevation View

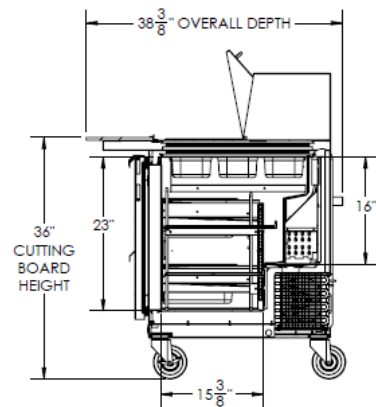

### Side View

### ELECTRICAL CONNECTION



115/60/1  
NEMA-5-15P

Units pre-wired at factory and include 8' long cord and plug set.



an Ali Group Company



The Spirit of Excellence

3779 Champion Blvd., Winston-Salem, NC 27105  
1-888-845-9800 Fax: 1-336-245-6453