



BEVERAGE-AIR

Project: _____

AIA#

Item: _____

Location: _____

SIS#

Approved: _____

FOOD PREPERATION TABLES

SPED72HC Elite Series Sandwich Prep

Hydrocarbon Series

MODELS:

SPED72HC-18C-2

SPED72HC Elite Series Sandwich Prep: Cutting Top Series

3 Year Parts/Labor Warranty
Additional 2 Year Compressor Warranty

CABINET CONSTRUCTION

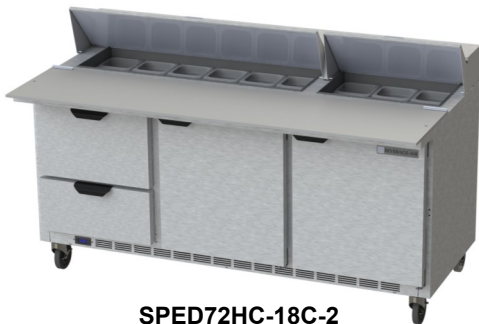

SPED72HC-18C-2

- Stainless steel front, sides, top, door(s), drawer(s), and grille (galvanized steel back & bottom)
- Interior liner is made of corrosion resistant aluminum
- Removable hoods & insulated lid assemblies are made of matching stainless steel
- Self-closing doors on cartridge style hinges, with 120° stay open feature
- Easy door removal for service and cleaning
- Field-reversible doors with snap-in door gaskets
- Painted aluminum door and drawer handle(s)
- 6" Casters, 2 with brakes standard
- Two epoxy-coated steel wire shelves per section standard
- 17" Wide cutting board constructed of white polyethylene plastic
- Cutting board removable for cleaning
- Pans furnished are 4" deep constructed of polycarbonate plastic
- Stainless steel drawer frames supported on telescoping drawer slides
- Drawer slides include locking mechanism that prevents drawers from being inadvertently pulled off cabinet
- Top and bottom drawers accommodate 6" deep pans

OPTIONS & ACCESSORIES

- Stainless steel back options
- Stainless steel interior options
- Combination models available
- Overshelves (single or double)
- Crumb catcher
- Modified pan openings
- 6" Legs
- 3" Casters
- Low profile casters
- Richlite cutting board
- Night cover
- Remote options

REFRIGERATION SYSTEM

- Refrigeration system uses R290 refrigerant to comply with all environmental concerns
- Recirculated, forced air from evaporator is moved under pans, which are recessed 2" from top of cabinet
- Automatic, non-electric evaporator
- System is serviceable from rear
- Epoxy coated evaporator coil



3779 Champion Blvd., Winston-Salem, NC 27105
1-888-845-9800 Fax: 1-336-245-6453
Beverage-Air.com sales@bevair.com



BEVERAGE-AIR

MODEL	SPED72HC-18C-2
EXTERNAL DIMENSIONAL DATA	
Width Overall	72"
Depth Overall	38 3/8"
Height Overall with 6" Casters	45 1/8"
Number of Doors	2
Depth with Door Open 90°	52 1/4"
Door Opening (in)	19 1/2" x 21 5/8"
Shelf Area (sq. in)	Upper 344 33/64 Lower 367 1/8 Upper 302 3/4 Lower 302 3/4
Number of Drawers	2
Depth with Top Drawers Open Extended	47 7/8"
Drawer Opening (in)	Upper 19 1/2" x 11 1/4" Lower 19 1/2" x 7 1/2"
Depth, Cutting Board	10"
INTERNAL DIMENSIONAL DATA	
NET Capacity (cubic ft.)	14.6
Internal Width Overall (in)	68"
Internal Depth Overall (in)	15 3/8"
Internal Height Overall (in)	23"
Number of Shelves	4
Number of Pans	(18) 1/6 Size
ELECTRICAL DATA	
Full Load Amperes 115/60/1	3
REFRIGERATION DATA	
Horsepower	1/4
Capacity (BTU/Hr)*	1549
WEIGHT DATA	
Gross Weight (Crated lbs)	468 lbs
Height - Crated	48"
Width - Crated	74"
Depth - Crated	38"

Food Preparation Table - Cutting Top

Models: SPED72HC-18C-2

Model Views

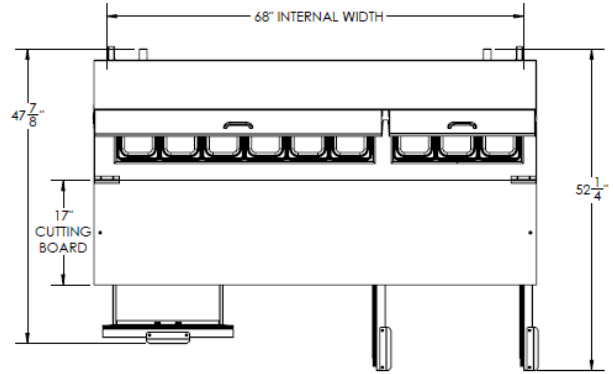

Plan View

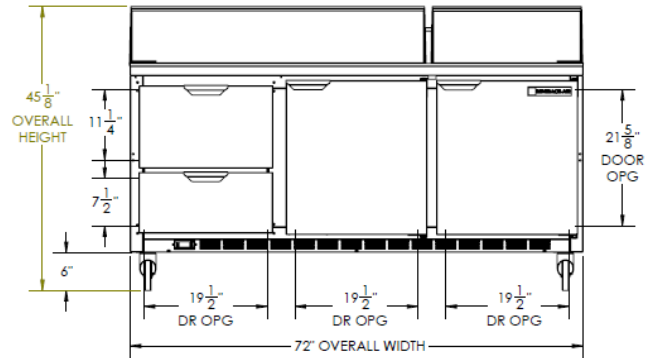

Elevation View

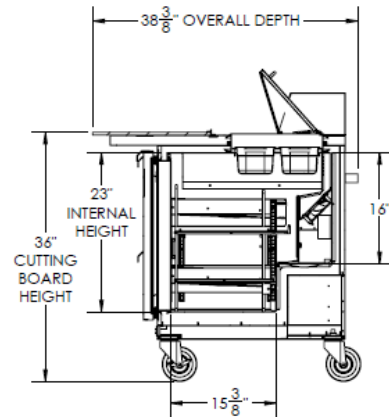

Side View

ELECTRICAL CONNECTION



115/60/1
NEMA-5-15P

Units pre-wired at factory and include 8' long cord and plug set.



an Ali Group Company



The Spirit of Excellence

3779 Champion Blvd., Winston-Salem, NC 27105
1-888-845-9800 Fax: 1-336-245-6453