



BEVERAGE-AIR

Project: _____

AIA#

Item: _____

Location: _____

SIS#

Approved: _____

UCR UNDERCOUNTER

UCR24AHC Undercounter Refrigerator Hydrocarbon Series

**MODELS:
UCR24AHC**



UCR24AHC

**3 Year Parts/Labor Warranty
Additional 2 Year Compressor Warranty**

CABINET CONSTRUCTION

- Stainless steel front, sides, top, door, (*galvanized steel back & bottom*)
- Interior liner is made of corrosion resistant aluminum
- Full electronic control
- Undercounter feature a 1/2" thick sub-top
- Interior thermometer is standard
- Self-closing door with 120° stay-open feature, on cartridge style hinges
- Easy door removal for service and cleaning
- Magnetic gasket attached to each door for positive seal
- Painted aluminum door handle
- 6" Casters, two (2) with brakes standard
- Two epoxy-coated steel wire shelves standard
- Field reversible door
- Maintains product temperature between 36°F and 38°F

OPTIONS & ACCESSORIES

- Stainless steel back and grille
- Stainless steel interior
- Right or left hinged door
- Locks (solid doors only)
- Bun rack
- Wire shelf divider
- 3" Casters or 6" legs
- Low profile casters
- Remote option

REFRIGERATION SYSTEM

- Refrigeration system uses R290 refrigerant to comply with all environmental concerns
- Automatic, non-electric defrost
- Epoxy coated evaporator coil

UCR24AHC Undercounter Refrigerator: Food Prep Series



3779 Champion Blvd., Winston-Salem, NC 27105
1-888-845-9800 Fax: 1-336-245-6453
Beverage-Air.com sales@bevair.com



BEVERAGE-AIR

Undercounter Refrigerators

Models: UCR24AHC

MODEL	UCR24AHC
EXTERNAL DIMENSIONAL DATA	
Width Overall	24"
Depth Overall	32"
Height Overall with 6" casters	34 5/8"
Number of Doors	1
Depth with Door Open 90 °	52 1/4"
Door Opening (in)	19 5/8" X 21 5/8"
INTERNAL DIMENSIONAL DATA	
NET Capacity (cubic ft.)	5.16
Internal Width Overall (in)	20"
Internal Depth Overall (in)	23 1/2"
Internal Depth Usable (in)	Upper 18 1/2" Lower 15 3/8"
Internal Height Overall (in)	23"
Internal Height Usable (in)	16"
Number of Shelves	2
ELECTRICAL DATA	
Full Load Amperes 115/60/1	2.0
REFRIGERATION DATA	
Horsepower	1/10
Capacity (BTU/Hr)*	1110
WEIGHT DATA	
Gross Weight (Crated lbs)	164 lbs
Height - Crated	34"
Width - Crated	30"
Depth - Crated	32"

Model Views

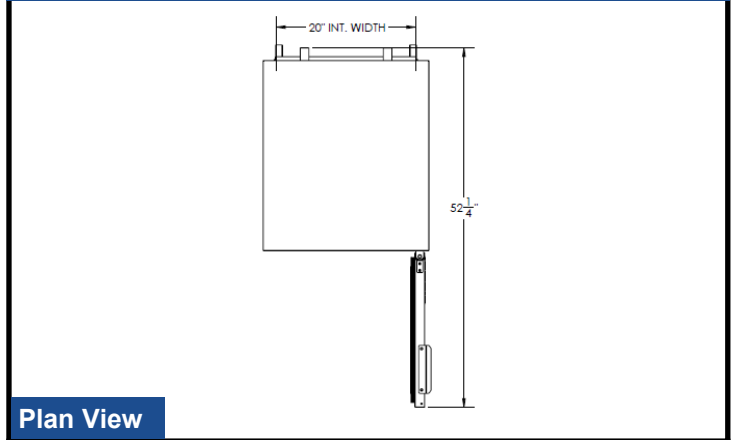

Plan View

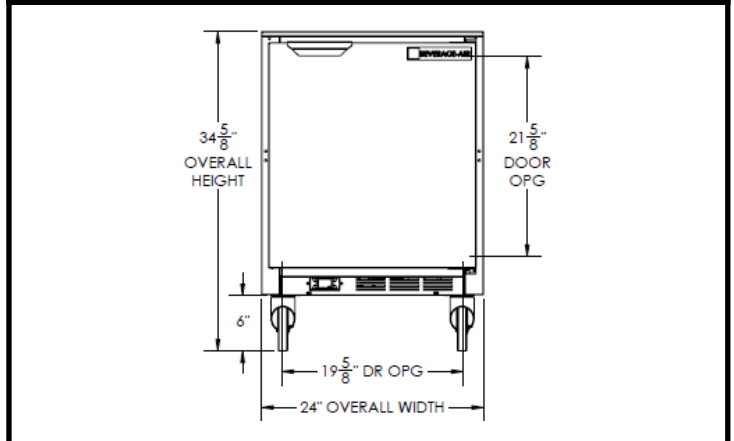

Elevation View

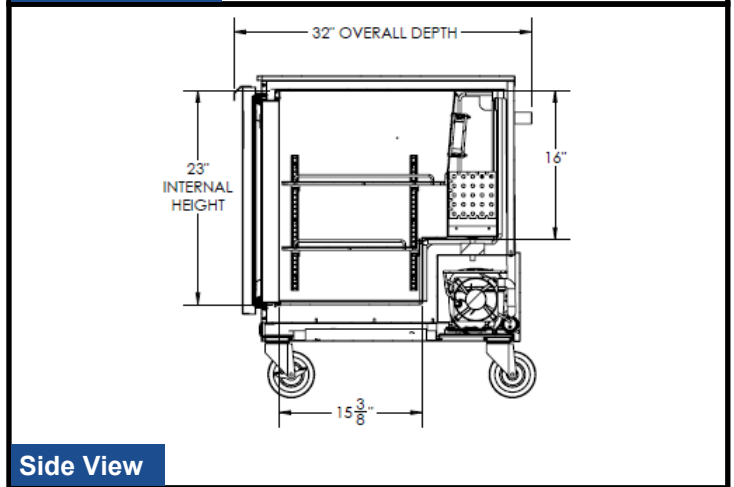

Side View

ELECTRICAL CONNECTION



115/60/1
NEMA-5-15P

Units pre-wired at factory and include 8' long cord and plug set.



an Ali Group Company



The Spirit of Excellence

3779 Champion Blvd., Winston-Salem, NC 27105
1-888-845-9800 Fax: 1-336-245-6453
Beverage-Air.com sales@bevair.com