



# BEVERAGE-AIR

Project: \_\_\_\_\_

AIA#

Item: \_\_\_\_\_

Location: \_\_\_\_\_

SIS#

Approved: \_\_\_\_\_

## WTR 29" DEPTH WORKTOP

### WTR36AHC Removable Backsplash Worktop Refrigerator Hydrocarbon Series

**MODELS:  
WTR36AHC**



**WTR36AHC**

**3 Year Parts/Labor Warranty  
Additional 2 Year Compressor Warranty**

### CABINET CONSTRUCTION

- Stainless steel front, sides and door(s), *galvanized back & bottom*
- Interior liner is made of corrosion resistant aluminum
- Stainless steel top
- 4" High removable backsplash
- Full electronic control
- Interior thermometer is standard
- Self-closing doors with 120° stay-open feature, on cartridge style hinges
- Easy door removal for service and cleaning
- Magnetic gasket attached to each door for positive seal
- Painted aluminum door handle(s)
- 6" Casters, two (2) with brakes standard
- Two epoxy-coated steel wire shelves per section standard
- Field-reversible door(s)
- Operates at 36° –38°F for optimum food preservation

### OPTIONS & ACCESSORIES

- Stainless steel back and grille
- Stainless steel interior
- Glass door with lock
- Solid door with lock
- Drawers units
- 6" Legs
- 3" Casters
- Low profile casters
- Cutting board
- Foot pedal door opener
- Remote options

### REFRIGERATION SYSTEM

- Refrigeration system uses R290 refrigerant to comply with all environmental concerns
- Automatic, non-electric evaporator
- System is serviceable from rear
- Epoxy coated evaporator coil

WTR36AHC 29" Worktop: Food Prep Series



3779 Champion Blvd., Winston-Salem, NC 27105  
1-888-845-9800 Fax: 1-336-245-6453  
Beverage-Air.com sales@bevair.com



# BEVERAGE-AIR

MODEL	WTR36AHC
<b>EXTERNAL DIMENSIONAL DATA</b>	
Width Overall	36"
Depth Overall with Handle & Bumper	32"
Height Overall with 6" Casters	39 5/8"
Number of Doors	2
Depth with Door Open 90°	46 1/4"
Clear Door Opening (in)	13 3/4" x 21 7/8"
Shelf Area (sq. in)	Upper 344 1/2" Lower 302 3/4"
<b>INTERNAL DIMENSIONAL DATA</b>	
NET Capacity (cubic ft.)	8.5
Internal Width Overall (in)	32"
Internal Depth Overall (in)	23 1/2"
Internal Depth Useable (in)	Upper 18 1/2" Lower 15 3/8"
Internal Height Front (in)	23"
Internal Height Rear (in)	16"
Number of Shelves	4
<b>ELECTRICAL DATA</b>	
Full Load Amperes 115/60/1	2
<b>REFRIGERATION DATA</b>	
Horsepower	1/6
Capacity (BTU/Hr)*	994
<b>WEIGHT DATA</b>	
Gross Weight (Crated lbs)	216 lbs
Height - Crated	35"
Width - Crated	38"
Depth - Crated	33"

## Worktop Refrigerator - 29" Depth

Models: WTR36AHC

### Model Views

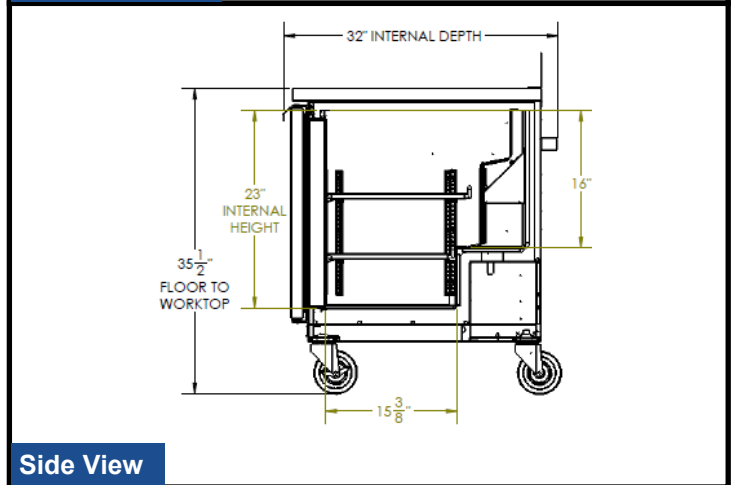
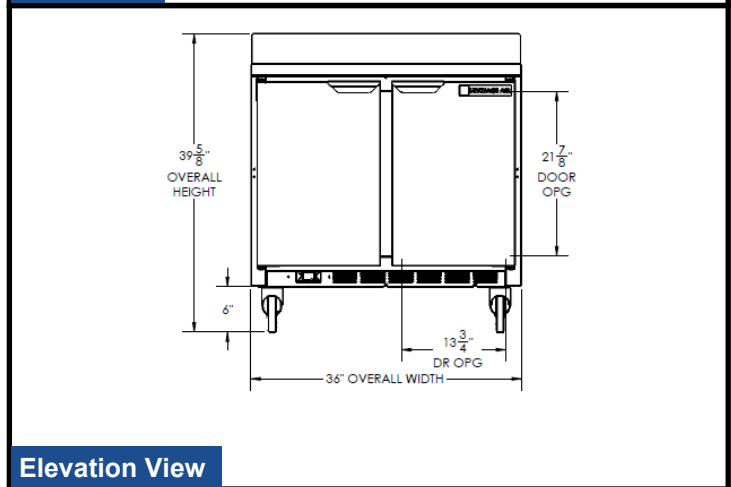
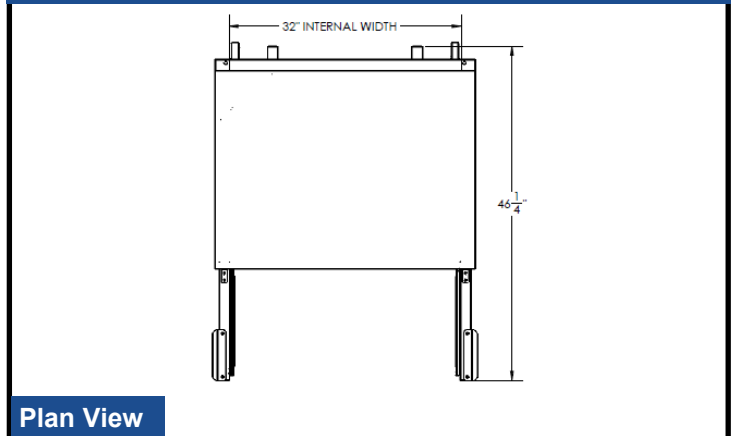

### ELECTRICAL CONNECTION



115/60/1  
NEMA-5-15P

Units pre-wired at factory and include 8' long cord and plug set.



an Ali Group Company



The Spirit of Excellence

3779 Champion Blvd., Winston-Salem, NC 27105  
1-888-845-9800 Fax: 1-336-245-6453  
Beverage-Air.com sales@bevair.com